

PRO-M Series Power Supplies

NEW



Weidmüller's new PRO-M Series Switchmode Power Supplies offer a host of advantages. Available in 10 different versions, the 24 VDC PRO-M power supplies all feature a solid ultra-slim metal housing, and are designed to mount on a DIN-rail with no ventilation gap required between multiple units. This feature provides up to a 50% savings in space and allows the PRO-M to fit into the tightest spaces in control cabinets or machines.

These compact and efficient power supplies are optimized for machinery, with features that include overload resistance and high performance reserves. They also provide an increased level of reliability. Should one phase fail, the three-phase PRO-M power supply modules continue to work reliably in a two-phase operation.

The PRO-M Series power supplies are available in single-phase and three-phase versions from 70 W to 1000 W, making them particularly suited for use in many automation applications. The wide-ranging AC and DC inputs, broad operating temperature range and international approvals make the PRO-M supplies a strong choice.

- Slim housings for space saving installation in the cabinet
- DIN-rail mountable without any gap (no clearance necessary)
- Operating temperature range of -25°C to $+70^{\circ}\text{C}$
- Autoselect Input for wide input range without any switch; for DC and AC voltages
- Power boost of 120% enables inductive and capacitive loads; additional starting capacity with up to a 2-minute boost
- Parallel connections allow simple power increase for up to five units without diode module
- MTBF > 500,000 Hours

Canada

Weidmüller, Canada
10 Spy Court
Markham, Ontario L3R 5H6
Telephone: (800) 268-4080
Facsimile: (877) 300-5635
Email: info1@weidmuller.ca
Website: www.weidmuller.ca

Mexico

Weidmüller, Mexico
Blvd. Hermanos Serdán 698
Col. San Rafael Oriente
Puebla, Puebla, Mexico
C.P. 72029
Telephone: 01 222 2686267
Facsimile: 01 222 2686219
Email: clientes@weidmuller.com.mx
Website: www.weidmuller.com.mx

United States

Weidmüller
821 Southlake Blvd.
Richmond, Virginia 23236
Telephone: (800) 849-9343
Facsimile: (804) 379-2593
Email: info@weidmuller.com
Website: www.weidmuller.com

Weidmüller 



Technical Data

General Specifications

Current limiting	> 120 % I _N
Ambient temp. operating / storage	-25 °C ... +70 °C / -40 °C ... +85 °C
Max. perm. air humidity (operation)	20 %...95 % RH
Protection class	IP20
Class of protection	I, with PE connection
Overvoltage category	II
Pollution severity	2
Insulation voltage	4 kV I/O / 2 kV I/ground / 0.5 kV O/ground
MTBF	> 500,000 h acc. to IEC 1709 (SN29500)
Protection against reverse voltages from the load	30...35 V DC
Parallel connection option	yes, without diode module
Housing version	metal, corrosion resistant
Indication	operation, green LED
Mounting position, installation notice	horizontal on mounting rail TS35, 50 mm spacing top and bottom for free air circulation, can be mounted side by side with no space in between

EMC / shock / vibration

Noise emission acc. to EN55022	Class B
Noise immunity tests acc. to	EN61000-4-2 (ESD), EN61000-4-3 and EN61000-4-8 (Fields), EN61000-4-4 (Burst), EN61000-4-5 (Surge), EN610004-6 (conducted), EN61000-4-11 (Dips)
Limiting of mains voltage harmonic currents	Acc. to EN 61000-3-2
Resistance against vibration and shock	Acc. to EN50178, shock: 5g in all directions

Electrical safety (applied standards)

Electrical equipment of machines	Acc. to EN60204
Safety transformers for switched-mode power units	Acc. to EN61558-2-17
Machinery with electronic equipment	Acc. to EN50178 / VDE0160
Safety extra-low voltage	SELV acc. to EN60950, PELV acc. to EN60204
Protective separation / protection against electrical shock	VDE0100-410 / acc. to DIN57100-410
Protection against dangerous shock currents	Acc. to VDE0106-101

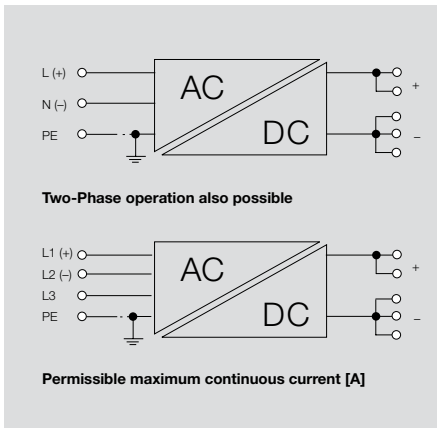

Max. limiting average on state current [A]

Type\Temp.	45°C	50°C	55°C	60°C	65°C	70°C
1ph 24V / 3A	3.6	3.3	3.0	2.6	2.2	1.8
1ph 24V / 5A	6	5.5	5.0	4.4	3.8	3.1
1ph 24V / 7.5A	9	8.6	8.25	7.5	6.75	5.6
1ph 24V / 10A	12	11.5	11	10	9	7.5
1ph 24V / 20A	24	23	22	20	18	15
1ph 24V / 40A	48	46	44	40	36	30
3ph 24V / 5A	6	5.75	5.5	5	4.5	3.7
3ph 24V / 10A	12	11.5	11	10	9	7.5
3ph 24V / 20A	24	23	22	20	18	15
3ph 24V / 40A	48	46	44	40	36	30

Project Planning Data

Type	24 V / 3 A	24 V / 5 A	24 V / 7.5 A	24 V / 10 A	24 V / 20 A	24 V / 40 A	24 V / 5 A	24 V / 10 A	24 V / 20 A	24 V / 40 A	
	1 - phase						3 - phase				
Rated input voltage	100...240 V AC						3 x 400...500 V AC				
Mains voltage range	85...264 V AC						3 x 320...575 V AC				
Mains input current (max/min)	1.9...0.6 A	3.2...1.0 A	4.7...1.6 A	3.2...1.1 A	6.4...2.1 A	12.7...4.1 A	0.4...0.2 A	0.7...0.4 A	1.3...0.7 A	2.6...1.2 A	
Rec. fuse [char..]	2 A / D I	4 A / D I	6 A / D I	6 A / D I	10 A / D I	16 A / D I	2 A / D I	2 A / D I	2 A / D I	4 A / D I	
	6 A, [B]	6 A, [B]	16 A, [B]	16 A, [B]	20 A, [B]	25 A, [B]	-	-	-	10 A, [B]	
	2...4 A, [C]	3...5 A, [C]	5...10 A, [C]	5...10 A, [C]	10...12 A, [C]	14...16 A, [C]	1...2 A, [C]	2...3 A, [C]	3...5 A, [C]	6...8 A, [C]	
Efficiency @ 230VAC	88%	89%	90%	90%	> 90%	> 90%	90%	> 90%	> 90%	> 90%	
Rated power loss [W]	10 W	15 W	20 W	27 W	53 W	106 W	13 W	26 W	53 W	107 W	
Installation width mm	33	40	50	60	121	180	40	60	121	180	
Input terminals	Screw connection										
Conductor, solid min/max mm ²	0.5...6			0.5...6			0.5...6		0.5...6		
Conductor, flexible min/max mm ²	0.5...2.5			0.5...2.5			0.5...2.5		0.5...2.5		
Conductor, AWG/kcmil min/max	26 / 12			26 / 10			26 / 12		26 / 12		
Output terminals	Screw connection										
Number plus/minus	2 / 2		2 / 3								
Conductor, solid min/max mm ²	0.5...6			0.5...6		0.5...16		0.5...6		0.5...16	
Conductor, flexible min/max mm ²	0.5...2.5			0.5...2.5		2.5...10		0.5...2.5		0.5...2.5	
Conductor, AWG/kcmil min/max	26 / 12			26 / 10		26 / 6		26 / 12		26 / 10	

CP M SNT 70W 24V 3A

CP M SNT 120W 24V 5A

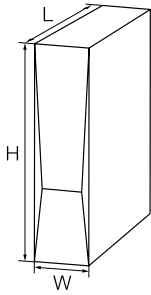

Derating Curve

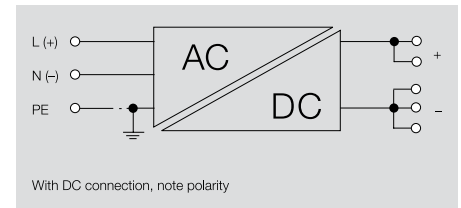
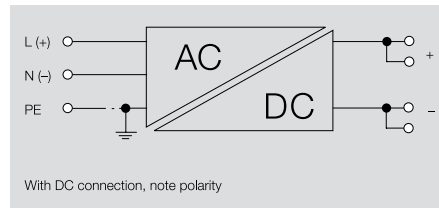
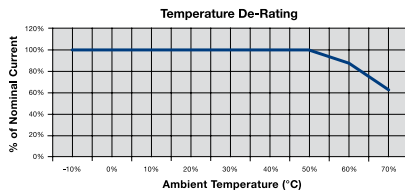

Ordering Data

Type	Part No.
CP M SNT 70W 24V 3A	8951330000

Type	Part No.
CP M SNT 120W 24V 5A	8951340000

Technical Data

Input Specifications	
Rated input voltage	
AC input voltage range	
AC frequency range	
DC input voltage range	
AC current consumption	
DC current consumption	
Input fuse (internal)/Inrush current	
Circuit Protection	
Output Specifications	
Rated output voltage	
Output voltage	
Residual ripple, switching peaks	
Rated output current @ V_{rated}	
Continuous output current @ 24 V DC	
Power boost @ 24 V DC, 60 °C	
General Specifications	
Efficiency	
Power factor (approx.)	
Mains buffering @ I_{rated}	
Parallel connection option	
Length x Width x Height	mm
Weight	
Approvals/Certifications	
Connection Data	
Type of connection	
Number of terminals	
Conductor cross-section, rigid min/max	mm ²
Conductor cross-section, flexible min/max	mm ²
Conductor cross-section, AWG/kcmil min/max	

100...240 V AC (wide-range input)	
85...264 V AC	
47...63 Hz	
80...370 V DC	
0.80 A @ 230 V AC / 1.5A @ 115 V AC	
0.25 A @ 370 V DC / 1.1 A @ 80 V DC	
yes/max. 20 A	
2 A / DI, safety fuse	
6 A, Char. B, Circuit breaker	
2...4 A, Char. C, Circuit breaker	
24 V DC ± 1 %	
22.5...29.5 V DC (adjustable via potentiometer on front)	
100 mV _{SS} @ 24 V DC, I_N	
3 A @ 55 °C	
3.6 A @ 45 °C	
3.3 A @ 50 °C	
1.8 A @ 70 °C	
3.6 A for 1 min, ED=5 %	
88 % @ 230 V AC / > 85 % @ 115 V AC	
> 0.5 @ 230 V AC / > 0.53 @ 115 V AC	
> 100 ms @ 230 V AC / > 20 ms @ 100 V AC	
yes	
125 x 33 x 130	
0.69 kg	
CE, cURus, UL508, CSA22.2 no.107	
Input	Output
Screw connection	Screw Connection
3 for L/N/PE	4 (++/-)
0.5 / 6	0.5 / 6
0.5 / 2.5	0.5 / 2.5
26 / 12	26 / 12

100...240 V AC (wide-range input)	
85...264 V AC	
47...63 Hz	
80...370 V DC	
1.3 A @ 230 V AC / 2.4 A @ 115 V AC	
0.5 A @ 370 V DC / 1.8 A @ 80 V DC	
yes/max. 30 A	
4 A / DI, safety fuse	
6 A, Char. B, Circuit breaker	
3...5 A, Char. C, Circuit breaker	
24 V DC ± 1 %	
22.5...29.5 V DC (adjustable via potentiometer on front)	
100 mV _{SS} @ 24 V DC, I_N	
5 A @ 55 °C	
6.0 A @ 45 °C	
5.5 A @ 50 °C	
3.1 A @ 70 °C	
6 A for 1 min, ED=5 %	
89 % @ 230 V AC / > 85 % @ 115 V AC	
> 0.5 @ 230 V AC / > 0.53 @ 115 V AC	
> 100 ms @ 230 V AC / > 20 ms @ 100 V AC	
yes	
125 x 40 x 130	
0.8 kg	
CE, cURus, UL508, CSA22.2 no.107	
Input	Output
Screw connection	Screw Connection
3 for L/N/PE	5 (++/-)
0.5 / 6	0.5 / 6
0.5 / 2.5	0.5 / 2.5
26 / 12	26 / 26

* Recommendation applies only for AC operation; the max. permissible operating voltage is to be observed in all cases!

* Recommendation applies only for AC operation; the max. permissible operating voltage is to be observed in all cases!

CP M SNT 180W 24V 7.5A

CP M SNT 250W 24V 10A

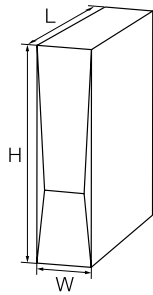

Derating Curve

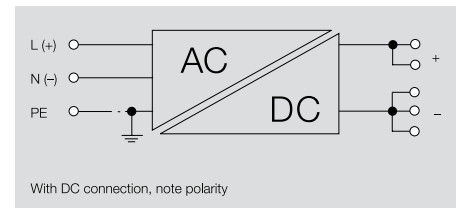
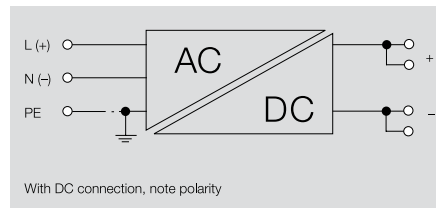
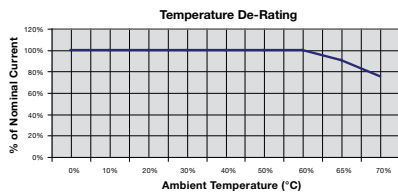

Ordering Data

Type	Part No.
CP M SNT 180W 24V 7.5A	8951350000

Type	Part No.
CP M SNT 250W 24V 10A	8951360000

Technical Data

Input Specifications	
Rated input voltage	100...240 V AC (wide-range input)
AC input voltage range	85...264 V AC
AC frequency range	47...63 Hz
DC input voltage range	80...370 V DC
AC current consumption	1.9 A @ 230 V AC / 3.6 A @ 115 V AC
DC current consumption	0.6 A @ 370 V DC / 2.6 A @ 80 V DC
Input fuse (internal)/Inrush current	yes
Circuit Protection	6 A / DI, safety fuse 16 A, Char. B, Circuit breaker 5...10 A, Char. C, Circuit breaker

Rated input voltage	100...240 V AC (wide-range input)
AC input voltage range	85...264 V AC
AC frequency range	47...63 Hz
DC input voltage range	80...370 V DC
AC current consumption	1.9 A @ 230 V AC / 3.6 A @ 115 V AC
DC current consumption	0.6 A @ 370 V DC / 2.6 A @ 80 V DC
Input fuse (internal)/Inrush current	yes
Circuit Protection	6 A / DI, safety fuse 16 A, Char. B, Circuit breaker 5...10 A, Char. C, Circuit breaker

Rated input voltage	100...240 V AC (wide-range input)
AC input voltage range	85...264 V AC
AC frequency range	47...63 Hz
DC input voltage range	80...370 V DC
AC current consumption	1.3 A @ 230 V AC / 2.5 A @ 115 V AC
DC current consumption	0.9 A @ 370 V DC / 3.4 A @ 80 V DC
Input fuse (internal)/Inrush current	yes
Circuit Protection	6 A / DI, safety fuse 16 A, Char. B, Circuit breaker 5...10 A, Char. C, Circuit breaker

Output Specifications	
Rated output voltage	24 V DC ± 1 %
Output voltage	22.5...29.5 V DC (adjustable via potentiometer on front)
Residual ripple, switching peaks	100 mVss @ 24 V DC, IN
Rated output current @ V _{rated}	7.5 A @ 60 °C
Continuous output current @ 24 V DC	9.0 A @ 45 °C 8.2 A @ 55 °C 5.6 A @ 70 °C
Power boost @ 24 V DC, 60 °C	9 A for 1 min, ED=5 %

Rated output voltage	24 V DC ± 1 %
Output voltage	22.5...29.5 V DC (adjustable via potentiometer on front)
Residual ripple, switching peaks	100 mVss @ 24 V DC, IN
Rated output current @ V _{rated}	7.5 A @ 60 °C
Continuous output current @ 24 V DC	9.0 A @ 45 °C 8.2 A @ 55 °C 5.6 A @ 70 °C
Power boost @ 24 V DC, 60 °C	9 A for 1 min, ED=5 %

Rated output voltage	24 V DC ± 1 %
Output voltage	22.5...29.5 V DC (adjustable via potentiometer on front)
Residual ripple, switching peaks	100 mVss @ 24 V DC, IN
Rated output current @ V _{rated}	10 A @ 60 °C
Continuous output current @ 24 V DC	12 A @ 45 °C 11 A @ 55 °C 7.5 A @ 70 °C
Power boost @ 24 V DC, 60 °C	12 A for 1 min, ED=5 %

General Specifications	
Efficiency	90 % @ 230 V AC / > 85 % @ 115 V AC
Power factor (approx.)	> 0.5 @ 230 V AC / > 0.53 @ 115 V AC
Mains buffering @ I _{rated}	> 40 ms @ 230 V AC / > 20 ms @ 100 V AC
Parallel connection option	yes
Length x Width x Height	150 x 50 x 130 mm
Weight	1.0 kg

Efficiency	90 % @ 230 V AC / > 85 % @ 115 V AC
Power factor (approx.)	> 0.5 @ 230 V AC / > 0.53 @ 115 V AC
Mains buffering @ I _{rated}	> 40 ms @ 230 V AC / > 20 ms @ 100 V AC
Parallel connection option	yes
Length x Width x Height	150 x 50 x 130 mm
Weight	1.0 kg

Efficiency	90 % @ 230 V AC / > 85 % @ 115 V AC
Power factor (approx.)	> 0.98 @ 230 V AC / > 0.98 @ 115 V AC
Mains buffering @ I _{rated}	> 40 ms @ 230 V AC / > 20 ms @ 100 V AC
Parallel connection option	yes
Length x Width x Height	150 x 60 x 130 mm
Weight	1.2 kg

Approvals/Certifications	
	CE, cURus, UL508, CSA22.2 no.107

	CE, cURus, UL508, CSA22.2 no.107
--	----------------------------------

	CE, cURus, UL508, CSA22.2 no.107
--	----------------------------------

Connection Data	
Type of connection	Screw connection
Number of terminals	3 for L/N/PE
Conductor cross-section, rigid min/max	0.5 / 6 mm ²
Conductor cross-section, flexible min/max	0.5 / 2.5 mm ²
Conductor cross-section, AWG/kcmil min/max	26 / 12

Input	Output
Screw connection	Screw Connection
3 for L/N/PE	5 (+/-/-)
0.5 / 6	0.5 / 6
0.5 / 2.5	0.5 / 2.5
26 / 12	26 / 12

Input	Output
Screw connection	Screw Connection
3 for L/N/PE	5 (+/-/-)
0.5 / 6	0.5 / 6
0.5 / 2.5	0.5 / 2.5
26 / 12	26 / 12

* Recommendation applies only for AC operation; the max. permissible operating voltage is to be observed in all cases!

* Recommendation applies only for AC operation; the max. permissible operating voltage is to be observed in all cases!

CP M SNT 500W 24V 20A

CP M SNT 1000W 24V 40A

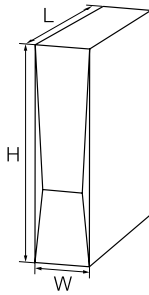

Derating Curve

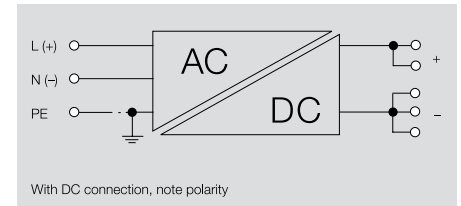
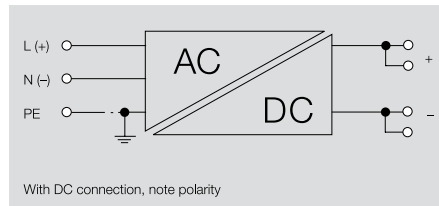
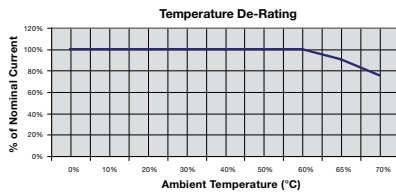

Ordering Data

Type	Part No.
CP M SNT 500W 24V 20A	8951370000

Type	Part No.
CP M SNT 1000W 24V 40A	8951380000

Technical Data

Input Specifications

Rated input voltage	100...240 V AC wide-range input
AC input voltage range	85...264 V AC
AC frequency range	47...63 Hz
DC input voltage range	80...370 V DC
AC current consumption	2.5 A @ 230 V AC / 4.9 A @ 115 V AC
DC current consumption	1.6 A @ 370 V DC / 6.8 A @ 80 V DC
Input fuse (internal)/Inrush current	yes
Circuit Protection	20 A / DI, safety fuse

Rated input voltage	100...240 V AC wide-range input
AC input voltage range	85...264 V AC
AC frequency range	47...63 Hz
DC input voltage range	80...370 V DC
AC current consumption	2.5 A @ 230 V AC / 4.9 A @ 115 V AC
DC current consumption	1.6 A @ 370 V DC / 6.8 A @ 80 V DC
Input fuse (internal)/Inrush current	yes
Circuit Protection	20 A / DI, safety fuse

Rated input voltage	100...240 V AC (wide-range input)
AC input voltage range	85...264 V AC
AC frequency range	47...63 Hz
DC input voltage range	80...370 V DC
AC current consumption	4.9 A @ 230 V AC / 9.6 A @ 115 V AC
DC current consumption	3.0 A @ 370 V DC / 13.5 A @ 80 V DC
Input fuse (internal)/Inrush current	yes
Circuit Protection	16 A / DI, safety fuse

Output Specifications

Rated output voltage	24 V DC ± 1 %
Output voltage	22.5...29.5 V DC (adjustable via potentiometer on front)
Residual ripple, switching peaks	100 mV _{SS} @ 24 V DC, I _N
Rated output current @ V _{rated}	20 A @ 60 °C
Continuous output current @ 24 V DC	24 A @ 45 °C
	22 A @ 55 °C
	15 A @ 70 °C
Power boost @ 24 V DC, 60 °C	24 A for 1 min, ED=5 %

Rated output voltage	24 V DC ± 1 %
Output voltage	22.5...29.5 V DC (adjustable via potentiometer on front)
Residual ripple, switching peaks	100 mV _{SS} @ 24 V DC, I _N
Rated output current @ V _{rated}	40 A @ 60 °C
Continuous output current @ 24 V DC	48 A @ 45 °C
	44 A @ 55 °C
	30 A @ 70 °C
Power boost @ 24 V DC, 60 °C	48 A for 1 min, ED=5 %

Rated output voltage	24 V DC ± 1 %
Output voltage	22.5...29.5 V DC (adjustable via potentiometer on front)
Residual ripple, switching peaks	100 mV _{SS} @ 24 V DC, I _N
Rated output current @ V _{rated}	40 A @ 60 °C
Continuous output current @ 24 V DC	48 A @ 45 °C
	44 A @ 55 °C
	30 A @ 70 °C
Power boost @ 24 V DC, 60 °C	48 A for 1 min, ED=5 %

General Specifications

Efficiency	> 90 % @ 230 V AC / > 85 % @ 115 V AC
Power factor (approx.)	> 0.98 @ 230 V AC / > 0.98 @ 115 V AC
Mains buffering @ I _{rated}	> 40 ms @ 230 V AC / > 20 ms @ 100 V AC
Parallel connection option	yes
Length x Width x Height	150 x 121 x 130 mm
Weight	1.5 kg

Efficiency	> 90 % @ 230 V AC / > 85 % @ 115 V AC
Power factor (approx.)	> 0.98 @ 230 V AC / > 0.98 @ 115 V AC
Mains buffering @ I _{rated}	> 40 ms @ 230 V AC / > 20 ms @ 100 V AC
Parallel connection option	yes
Length x Width x Height	150 x 121 x 130 mm
Weight	1.5 kg

Efficiency	> 90 % @ 230 V AC / > 85 % @ 115 V AC
Power factor (approx.)	> 0.98 @ 230 V AC / > 0.98 @ 115 V AC
Mains buffering @ I _{rated}	> 40 ms @ 230 V AC / > 20 ms @ 100 V AC
Parallel connection option	yes
Length x Width x Height	150 x 180 x 130 mm
Weight	1.5 kg

Approvals/Certifications

CE, cURus, UL508, CSA22.2 no.107

CE, cURus, UL508, CSA22.2 no.107

Connection Data

Type of connection	Number of terminals	Conductor cross-section, rigid min/max	Conductor cross-section, flexible min/max	Conductor cross-section, AWG/kcmil min/max
Screw connection	3 for L/N/PE	0.5 / 6 mm ²	0.5 / 2.5 mm ²	26 / 10

Input	Output
Screw connection	Screw Connection
3 for L/N/PE	5 (+/-/---)
0.5 / 6	0.5 / 6
0.5 / 2.5	0.5 / 2.5
26 / 10	26 / 10

Input	Output
Screw connection	Screw Connection
3 for L/N/PE	5 (+/-/---)
0.5 / 6	0.5 / 16
0.5 / 2.5	2.5 / 10
26 / 10	26 / 6

* Recommendation applies only for AC operation; the max. permissible operating voltage is to be observed in all cases!

* Recommendation applies only for AC operation; the max. permissible operating voltage is to be observed in all cases!

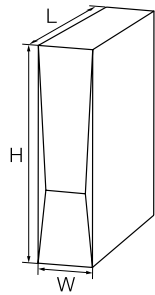

CP M SNT3 120W 24V 5A



CP M SNT3 250W 24V 10A



Derating Curve

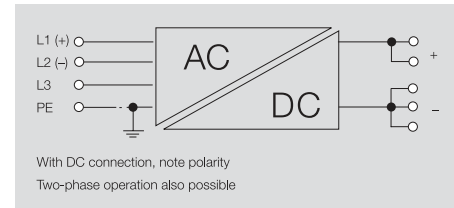
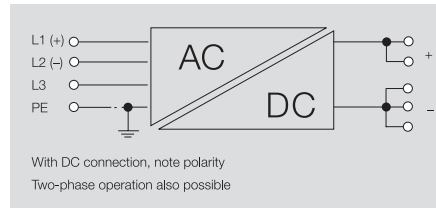
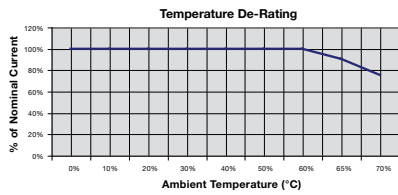

Ordering Data

Type	Part No.
CP M SNT3 120W 24V 5A	8951390000

Type	Part No.
CP M SNT3 250W 24V 10A	8951400000

Technical Data

Input Specifications	
Rated input voltage	3 x 400...3 x 500 V AC (wide-range input)
AC input voltage range	3 x 320...3 x 575 V AC / 2 x 360...2 x 575 V AC
AC frequency range	47...63 Hz
DC input voltage range	450...800 V DC (max. 500 V DC acc. to UL508)
AC current consumption	0.25 A @ 3 x 500 V AC / 0.3 A @ 3 x 400 V AC
DC current consumption	0.2 A @ 800 V DC / 0.4 A @ 450 V DC
Input fuse (internal)	no
Circuit Protection	2 A / DI, safety fuse

Rated input voltage	3 x 400...3 x 500 V AC (wide-range input)
AC input voltage range	3 x 320...3 x 575 V AC / 2 x 360...2 x 575 V AC
AC frequency range	47...63 Hz
DC input voltage range	450...800 V DC (max. 500 V DC acc. to UL508)
AC current consumption	0.25 A @ 3 x 500 V AC / 0.3 A @ 3 x 400 V AC
DC current consumption	0.2 A @ 800 V DC / 0.4 A @ 450 V DC
Input fuse (internal)	no
Circuit Protection	2 A / DI, safety fuse

Rated input voltage	3 x 400...3 x 500 V AC (wide-range input)
AC input voltage range	3 x 320...3 x 575 V AC / 2 x 360...2 x 575 V AC
AC frequency range	47...63 Hz
DC input voltage range	450...800 V DC (max. 500 V DC acc. to UL508)
AC current consumption	0.5 A @ 3 x 500 V AC / 0.6 A @ 3 x 400 V AC
DC current consumption	0.4 A @ 800 V DC / 0.7 A @ 450 V DC
Input fuse (internal)	no
Circuit Protection	2 A / DI, safety fuse

Output Specifications	
Rated output voltage	24 V DC ± 1 %
Output voltage	22.5...29.5 V DC (adjustable via potentiometer on front)
Residual ripple, switching peaks	100 mV _{SS} @ 24 V DC, I _N
Rated output current @ V _{rated}	5 A @ 60 °C
Continuous output current @ 24 V DC	6.0 A @ 45 °C 5.5 A @ 55 °C 3.7 A @ 70 °C
Power boost @ 24 V DC, 60 °C	6 A for 1 min, ED=5 %

Rated output voltage	24 V DC ± 1 %
Output voltage	22.5...29.5 V DC (adjustable via potentiometer on front)
Residual ripple, switching peaks	100 mV _{SS} @ 24 V DC, I _N
Rated output current @ V _{rated}	10 A @ 60 °C
Continuous output current @ 24 V DC	12 A @ 45 °C 11 A @ 55 °C 7.5 A @ 70 °C
Power boost @ 24 V DC, 60 °C	12 A for 1 min, ED=5 %

Rated output voltage	24 V DC ± 1 %
Output voltage	22.5...29.5 V DC (adjustable via potentiometer on front)
Residual ripple, switching peaks	100 mV _{SS} @ 24 V DC, I _N
Rated output current @ V _{rated}	10 A @ 60 °C
Continuous output current @ 24 V DC	12 A @ 45 °C 11 A @ 55 °C 7.5 A @ 70 °C
Power boost @ 24 V DC, 60 °C	12 A for 1 min, ED=5 %

General Specifications	
Efficiency	90 % @ 3 x 500 V AC / > 90 % @ 3 x 400 V AC
Power factor (approx.)	> 0.75 @ 3 x 500 V AC / > 0.78 @ 3 x 400 V AC
Mains buffering @ I _{rated}	> 25 ms @ 3 x 500 V AC / > 20 ms @ 3 x 400 V AC
Parallel connection option	yes
Length x Width x Height	125 x 40 x 130 mm
Weight	0.55 kg

Efficiency	90 % @ 3 x 500 V AC / > 90 % @ 3 x 400 V AC
Power factor (approx.)	> 0.75 @ 3 x 500 V AC / > 0.78 @ 3 x 400 V AC
Mains buffering @ I _{rated}	> 25 ms @ 3 x 500 V AC / > 20 ms @ 3 x 400 V AC
Parallel connection option	yes
Length x Width x Height	150 x 60 x 130 mm
Weight	0.9 kg

Efficiency	90 % @ 3 x 500 V AC / > 90 % @ 3 x 400 V AC
Power factor (approx.)	> 0.75 @ 3 x 500 V AC / > 0.78 @ 3 x 400 V AC
Mains buffering @ I _{rated}	> 25 ms @ 3 x 500 V AC / > 20 ms @ 3 x 400 V AC
Parallel connection option	yes
Length x Width x Height	150 x 60 x 130 mm
Weight	0.9 kg

Approvals/Certifications	
	CE, cURus, UL508, CSA22.2 no.107

	CE, cURus, UL508, CSA22.2 no.107
--	----------------------------------

	CE, cURus, UL508, CSA22.2 no.107
--	----------------------------------

Connection Data	
Type of connection	Screw connection
Number of terminals	4 for L1/L2/L3/PE
Conductor cross-section, rigid min/max	0.5 / 6 mm ²
Conductor cross-section, flexible min/max	0.5 / 2.5 mm ²
Conductor cross-section, AWG/kcmil min/max	26 / 12

Input	Output
Screw connection	Screw Connection
4 for L1/L2/L3/PE	5 (++)/---
0.5 / 6	0.5 / 6
0.5 / 2.5	0.5 / 2.5
26 / 12	26 / 12

Input	Output
Screw connection	Screw Connection
4 for L1/L2/L3/PE	5 (++)/---
0.5 / 6	0.5 / 6
0.5 / 2.5	0.5 / 2.5
26 / 12	26 / 12

* Recommendation applies only for AC operation; the max. permissible operating voltage is to be observed in all cases!

* Recommendation applies only for AC operation; the max. permissible operating voltage is to be observed in all cases!

CP M SNT3 500W 24V 20A

CP M SNT3 1000W 24V 40A

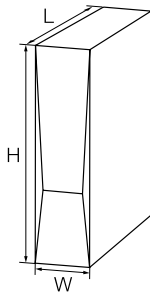

Derating Curve

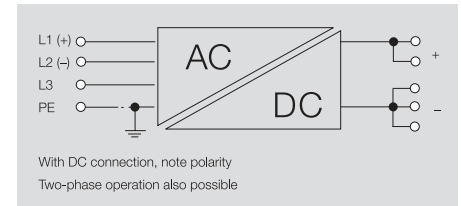
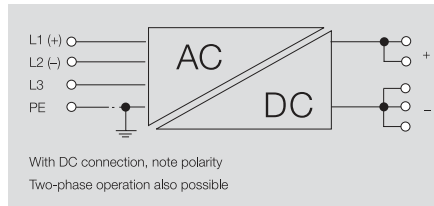
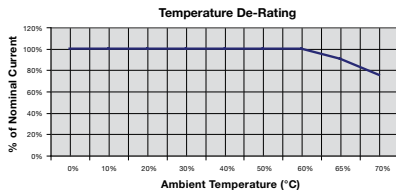

Ordering Data

Type	Part No.
CP M SNT3 500W 24V 20A	8951410000

Type	Part No.
CP M SNT3 1000W 24V 40A	8951420000

Technical Data

Input Specifications

Rated input voltage
AC input voltage range
AC frequency range
DC input voltage range
AC current consumption
DC current consumption
Input fuse (internal)
Circuit Protection

3 x 400...3 x 500 V AC (wide-range input)
3 x 320...3 x 575 V AC / 2 x 360...2 x 575 V AC
47...63 Hz
450...800 V DC (max. 500 V DC acc. to UL508)
0.9 A @ 3 x 500 V AC / 1.1 A @ 3 x 400 V AC
0.7 A @ 800 V DC / 1.3 A @ 450 V DC
no
2 A / DI, safety fuse
3...5 A, Char. C, Circuit breaker

3 x 400...3 x 500 V AC (wide-range input)
3 x 320...3 x 575 V AC / 2 x 360...2 x 575 V AC
47...63 Hz
450...800 V DC (max. 500 V DC acc. to UL508)
1.8 A @ 3 x 500 V AC / 2.1 A @ 3 x 400 V AC
1.4 A @ 800 V DC / 2.5 A @ 450 V DC
no
4 A / DI, safety fuse
10 A, Char. B, Circuit breaker
6...8 A, Char. C, Circuit breaker

Output Specifications

Rated output voltage
Output voltage
Residual ripple, switching peaks
Rated output current @ V_{rated}
Continuous output current @ 24 V DC
Power boost @ 24 V DC, 60 °C

24 V DC \pm 1 %
22.5...29.5 V DC (adjustable via potentiometer on front)
100 mV _{SS} @ 24 V DC, I_N
20 A @ 60 °C
24 A @ 45 °C
22 A @ 55 °C
15 A @ 70 °C
24 A for 1 min, ED=5 %

24 V DC \pm 1 %
22.5...29.5 V DC (adjustable via potentiometer on front)
100 mV _{SS} @ 24 V DC, I_N
40 A @ 60 °C
48 A @ 45 °C
44 A @ 55 °C
30 A @ 70 °C
48 A for 1 min, ED=5 %

General Specifications

Efficiency
Power factor (approx.)
Mains buffering @ I_{rated}
Parallel connection option
Length x Width x Height
Weight

> 90 % @ 3 x 500 V AC / > 91 % @ 3 x 400 V AC
> 0.75 @ 3 x 500 V AC / > 0.78 @ 3 x 400 V AC
> 25 ms @ 3 x 500 V AC / > 20 ms @ 3 x 400 V AC
yes
150 x 121 x 130
1.5 kg

> 90 % @ 3 x 500 V AC / 92 % @ 3 x 400 V AC
> 0.75 @ 3 x 500 V AC / > 0.78 @ 3 x 400 V AC
> 25 ms @ 3 x 500 V AC / > 20 ms @ 3 x 400 V AC
yes
150 x 180 x 130
2.9 kg

Approvals/Certifications

CE, cURus, UL508, CSA22.2 no.107

CE, cURus, UL508, CSA22.2 no.107

Connection Data

Type of connection	Number of terminals	Conductor cross-section, rigid min/max	Conductor cross-section, flexible min/max	Conductor cross-section, AWG/kcmil min/max
Screw connection				
4				
mm ²				
mm ²				

Input	Output
Screw connection	
4 for L1/L2/L3/PE	
5 (+/-/-/-)	
0.5 / 6	
0.5 / 2.5	
26 / 10	

Input	Output
Screw connection	
4 for L1/L2/L3/PE	
5 (+/-/-/-)	
0.5 / 6	
0.5 / 2.5	
26 / 10	
0.5 / 16	
0.5 / 10	
26 / 6	

* Recommendation applies only for AC operation; the max. permissible operating voltage is to be observed in all cases!

* Recommendation applies only for AC operation; the max. permissible operating voltage is to be observed in all cases!

PRO-M: Diode Modules

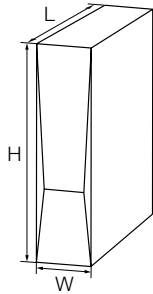

CP M DM20



CP DM40

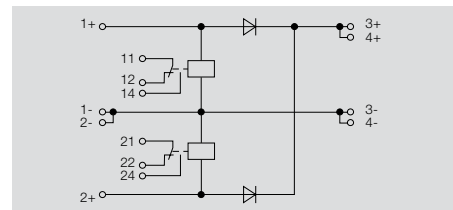
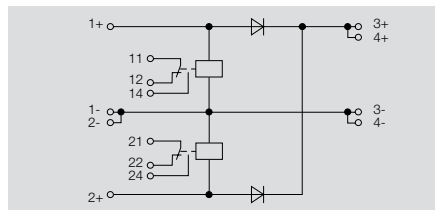

Ordering Data

Technical Data

Input Specifications

Rated input voltage
Input voltage range AC
Input current

Output Specifications

Rated output voltage
Output voltage
Rated (nominal) output current @ U_N
Continuous output current @ 24 V DC

Voltage monitoring
Switching thresholds

Potential free, floating contacts

General Specifications

Degree of efficiency
Length x width x height mm
Weight
Ambient temperature (operational) / Storage temperature
Max. permitted humidity (operational)
Degree of protection
Class of protection
Pollution degree
Insulation voltage I/O to housing
MTBF
Mounting position, installation notice

EMC / shock / vibration

Noise emission acc. to EN55022
Noise immunity tests acc. to
Resistance against vibration and shock

Electrical safety (applied standards)

Electrical equipment of machines
Safety transformers for switched-mode power units
Safety extra low voltage

Approvals

Pending

Connection data

Conductor connection system
Number of terminals
Conductor cross section, rigid min/max mm²
Conductor cross section, flexible min/max mm²
Conductor cross section, AWG/kcmil min/max

Type	Part No.
CP M DM20	1222210000

24 V DC
18...30 V DC
2 x 10 A or 1 x 20 A
24 V DC
Input voltage - 0.7 V
20 A DC @ 60 °C
24 A @ 45 °C
22.5 A @ 55 °C
15 A @ 70 °C
yes, in both inputs
21.6 V DC, relay is on for Power Good
20.4 V DC, relay is off for Power Fail
Max. 30 V DC / 1 A, CO contact

> 97 % @ 24 V input voltage
150 x 34 x 130
0.3 kg
-25...+70 °C / -40 °C...+85 °C
5 %...95 % RH
IP20
III, without PE connection, for SELV
2
0.5 kV
> 500.000 h according to IEC 1709 (SN29500)
Horizontal on TS35 mounting rail, with 50 mm space at top and bottom. Direct side by side mounting allowed.

Class B
EN61000-4-2 (ESD), EN61000-4-3 and EN61000-4-8 (Fields), EN61000-4-4 (Burst), EN61000-4-5 (Surge), EN610004-6 (conducted)
1 g according to EN50178 / 15 g in all directions

according to EN60204
according to EN50178 / VDE0160
SELV according to EN60950, PELV according to EN60204

CE, TUV, cCSAus, GL, GOST

Input	Output
Screw connection	Screw connection
4 (1+, 2+, 1-, 2-)	4 (3+, 4+, 3-, 4-)
0.5 / 6	0.5 / 6
0.5 / 2,5	0.5 / 2,5
26 / 12	26 / 12

Type	Part No.
CP M DM40	1222220000

24 V DC
18...30 V DC
2 x 20 A or 1 x 40 A
24 V DC
Input voltage - 0.7 V
40 A @ 60 °C
48 A @ 45 °C
45 A @ 55 °C
30 A @ 70 °C
yes, in both inputs
21.6 V DC, relay is on for Power Good
20.4 V DC, relay is off for Power Fail
Max. 30 V DC / 1 A, CO contact

> 97 % @ 24 V input voltage
150 x 60 x 130
0.6 kg
-25...+70 °C / -40 °C...+85 °C
5 %...95 % RH
IP20
III, without PE connection, for SELV
2
0.5 kV
> 500.000 h according to IEC 1709 (SN29500)
Horizontal on TS35 mounting rail, with 50 mm space at top and bottom. Direct side by side mounting allowed.

Class B
EN61000-4-2 (ESD), EN61000-4-3 and EN61000-4-8 (Fields), EN61000-4-4 (Burst), EN61000-4-5 (Surge), EN610004-6 (conducted)
1 g according to EN50178 / 15 g in all directions

according to EN60204
according to EN50178 / VDE0160
SELV according to EN60950, PELV according to EN60204

CE, TUV, cULus, GL, GOST

Input	Output
Screw connection	Screw connection
4 (1+, 2+, 1-, 2-)	4 (3+, 4+, 3-, 4-)
0.5 / 16	0.5 / 16
2.5 / 10	2.5 / 10
22 / 6	22 / 6

PRO-M: Relay Module

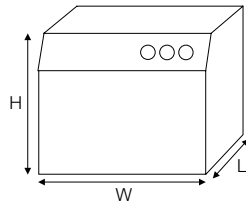

CP M RM24

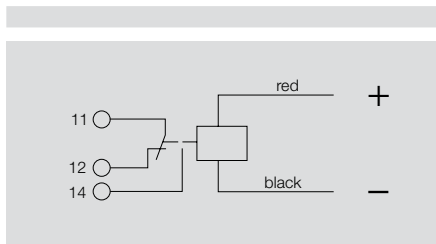

Ordering Data

Type	Part No.
CP M RM24	122230000

Technical Data

Input Specifications

Rated input voltage	24 V DC
Input voltage range DC	18...30 V DC

Output Specifications

Voltage monitoring	yes
Switching thresholds	21.6 V DC, relay is on for Power Good 20.4 V DC, relay is off for Power Fail
Potential free, floating contacts	Max. 30 V DC / 1 A, CO contact

General Specifications

Length x width x height	mm	22 x 33 x 28
Weight		75 g
Ambient temperature (operational) / Storage temperature		-25...+70 °C / -40 °C...+85 °C
Max. permitted humidity (operational)		5 %...95 % RH
Degree of protection		IP20
Class of protection		III, without PE connection, for SELV
Pollution degree		2
Insulation voltage I/O to housing		0,5 kV
MTBF		> 500.000 h according to IEC 1709 (SN29500)
Mounting position, installation notice		Plugged in to the front of the PRO-M power supply

EMC / shock / vibration

Noise emission acc. to EN55022	Class B
Noise immunity tests acc. to	EN61000-4-2 (ESD), EN61000-4-3 and EN61000-4-8 (Fields), EN61000-4-4 (Burst), EN61000-4-5 (Surge), EN610004-6 (conducted), EN61000-4-11 (Dips)
Resistance against vibration and shock	1 g according to EN50178 / 15 g in all directions

Electrical safety (applied standards)

Electrical equipment of machines	according to EN60204
Safety transformers for switch mode power units	according to EN50178 / VDE0160
Safety extra low voltage	SELV according to EN60950, PELV according to EN60204

Approvals

Pending	CE, TUV, cULus, GL, GOST
---------	--------------------------

Connection data

Conductor connection system		Input	Output
Number of terminals		10 cm cable (red/black) with ferrules	PUSH IN
Conductor cross section, rigid min/max	mm ²		3 (Changeover contact)
Conductor cross section, flexible min/max	mm ²		0.2 / 1.5
Conductor cross section, AWG/kcmil min/max			0.2 / 1.5
			24 / 16

PRO-M: Capacity Module



CP M CAP



Pulse triggering for cable circuit breakers:
with the Weidmüller capacitance module

The following conditions apply to the table entries:

- Ambient temperature of 20 °C
- Inner resistance of the circuit breakers is taken into account
- Half of the rated current flows to a neighbouring circuit before the short circuit is formed
- DC-compatible circuit breakers: Siemens 5SY series

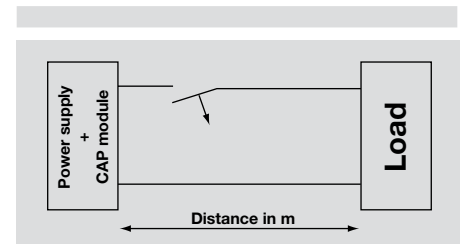
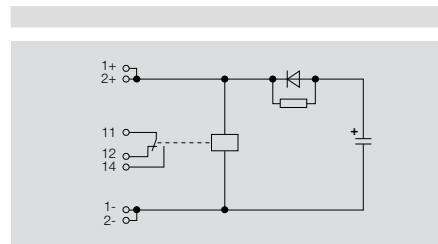

Ordering Data

Technical Data

Input Specifications	
Rated input voltage	
Input voltage range DC	

Output Specifications	
Peak current output	
Recovery time for the capacitor	
Voltage monitoring	
Switching thresholds	
Potential free, floating contacts	

General Specifications	
Length x width x height	mm
Weight	
Ambient temperature (operational) / Storage temperature	
Max. permitted humidity (operational)	
Degree of protection	
Class of protection	
Pollution degree	
Insulation voltage I/O to housing	
MTBF	
Mounting position, installation notice	

EMC / shock / vibration	
Noise emission acc. to EN55022	
Noise immunity tests acc. to	
Resistance against vibration and shock	

Electrical safety (applied standards)	
Electrical equipment of machines	
Safety transformers for switch mode power units	
Safety extra low voltage	

Approvals	
Pending	

Connection data	
Conductor connection system	
Number of terminals	
Conductor cross section, rigid min/max	mm²
Conductor cross section, flexible min/max	mm²
Conductor cross section, AWG/kcmil min/max	

Type	Part No.
CP M CAP	1222240000

24 V DC
18...30 V DC

Depending on load
approx. 1 s
yes
21.6 V DC, relay is on for Power Good
20.4 V DC, relay is off for Power Fail
Max. 30 V DC / 1 A, CO contact

150 x 34 x 130
0.4 kg
-25...+70 °C / -40 °C...+85 °C
5 %...95 % RH
IP20
III, without PE connection, for SELV
2
0.5 kV
> 500.000 h according to IEC 1709 (SN29500)
Horizontal on TS35 mounting rail, with 50 mm space at top and bottom. Direct side by side mounting allowed

Class B
EN61000-4-2 (ESD), EN61000-4-3 and EN61000-4-8 (Fields), EN61000-4-4 (Burst), EN61000-4-5 (Surge), EN610004-6 (conducted), EN61000-4-11 (Dips)
1 g according to EN50178 / 15 g in all directions

according to EN60204
according to EN50178 / VDE0160
SELV according to EN60950, PELV according to EN60204

CE, TUV, GL
cULus, GOST

Input	Output
Screw connection	Screw connection
4 (+--+)	3 (Changeover contact)
0.5 / 6	0.5 / 6
0.5 / 4	0.5 / 2.5
26 / 12	26 / 12

Fuse Tripping

Conductor cross section	B6	B10
0.75 mm²	10 m	
1.0 mm²	14 m	6 m
1.5 mm²	20 m	9 m
2.5 mm²	30 m	15 m
4 mm²	50 m	24 m
6 mm²		

B16		
0.75 mm²		
1.0 mm²		
1.5 mm²	4 m	
2.5 mm²	6 m	
4 mm²	10 m	
6 mm²	16 m	

C2 C4		
0.75 mm²	11 m	6 m
1.0 mm²	14 m	8 m
1.5 mm²	21 m	12 m
2.5 mm²	34 m	19 m
4 mm²		32 m
6 mm²		

C6 C10		
0.75 mm²	3 m	
1.0 mm²	3,5 m	2 m
1.5 mm²	5,5 m	3 m
2.5 mm²	9 m	5 m
4 mm²	14 m	8 m
6 mm²		12 m