





Overview Buzzer, Sirens, Horns and Sounders

Audible signals are everywhere!

Audible signals warn, protect and guide us in the modern industrial world. They function where caution, prudence and clarity are imperative, indicate emergencies and demand direct action. They are globally understood, irrespective of language, written or spoken.

Audible signals are deployed where an optical signal is insufficient or inappropriate. The basic signal is provided by one or more tones or a sequence of tones, raising awareness and alerting to a specific danger.

Overview Buzzer, Sirens, Horns and Sounders					
Product type		Installation	Free-standing	Free-standing	Free-standing
Category	Product range	Installation Sirens and Buzzer	EvoSIGNAL Mini	EvoSIGNAL Midi	Horns & Sounders
Dimensions (Ø x Height)*		starting on page 210	starting on page 169	starting on page 173	starting on page 177
Dimensions (L x H x W)					
Voltage	12 V	●	●	●	●
	24 V	●	●	●	●
	30 V				
	48 V	●			●
	115 V	●	●	●	●
	230 V	●	●	●	●
Audible	Continuous tone	●	●		●
	Pulse tone	●	●		●
	Multi-tone sounder	●		●	●
	Horn				●
	Alternating tone				●
	Vocal alarm				
Alarm bell					
Protection rating		IP30-65	IP33-65	IP66	IP33-65
Signalisation index**		1-5	4-5	8	6-7
Page		Page 210	Page 169	Page 173	Page 177

* Technical diagrams can be found on the product page

** Signalisation index - see page 13 + 21





				
Free-standing	Free-standing	Free-standing	Free-standing	Free-standing
Design Multi-Tone Sounder	Vocal alarm	Heavy Duty Multi-Tone Sounder	Alarm Bell	Ex Horns and Sirens
starting on page 184	starting on page 189	starting on page 191	starting on page 198	starting on page 200
•		•		
•	•	•	•	•
				•
•		•		•
•		•	•	•
				•
•		•		•
				•
	•			
			•	
IP65	IP65	up to IP67	IP66	IP65
8	6	6-10	5	4-6
Page 184	Page 189	Page 191	Page 198	Page 200

Installation Buzzers and Sounders

Your benefits

WERMA Installation Buzzers and Sounders have been specifically designed for easy installation in control panels.

- Quick and easy installation
- Tamper-proof when installed
- Minimal protrusion from panel installations where space is tight

Typical applications

Signalling faults or status messages

- in control cabinets

Installation options

- Installation mounting

Features

- Proven piezo technology (except 338, 382)

107, 109, 110, 111

- High IP65 protection rating for outdoor applications
- Easy to connect using a plug-in connection
- Up to 8 tones for signalling different statuses



Signalisation index				
	107	109	110	111
Continuous Tone	█ 1	█ 3		
Pulse Tone	█ 2	█ 4		█ 3
Multi-Tone Sounder			█ 5	█ 4
	338	382	114	118 + 119
Continuous Tone	█ 1	█ 4	█ 3	█ 4
Pulse Tone	█ 1			█ 4

107 Electronic Installation Buzzer



① TECHNICAL SPECIFICATIONS/ORDER SPECIFICATIONS:				
Dimensions (Ø x Height):	28 mm x 12 mm (Protrusion from panel)			
Housing:	PA fibreglass, high-impact			
Tone frequency:	c. 2,400 Hz / c. 3,200 Hz (12 V)			
Tone type:	Continuous tone or pulse tone with approx. 1 Hz			
Fixing:	Installation mounting for Ø 22.5 mm (M22)			
Connection:	Connector plug with screw terminal max. 1.5 mm ²			
Life duration:	> 5,000 hrs			
Voltage:	12 V DC	24 V AC/DC	115 V AC/DC	230 V AC
Current consumption:	≤ 10 mA	≤ 8 mA	≤ 8 mA	≤ 8 mA
Continuous tone	107 000 54	107 000 75	107 000 77	107 000 68
Pulse tone	107 010 54	107 010 75	107 010 77	107 010 68

↔ TECHNICAL DIAGRAM:



Simple connection by means of connector plug

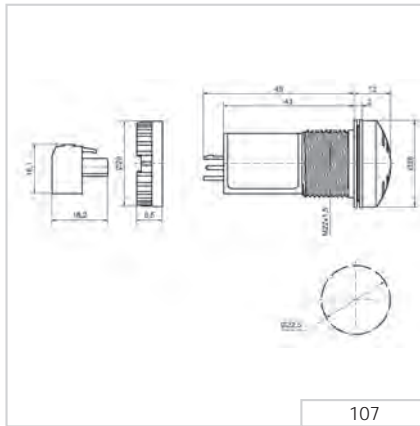

High protection rating IP 65 for use in arduous conditions

Signalisation index		
Continuous tone		1
Pulse tone		2

107 0X0 7X
107 0X0 68



109 Electronic Installation Buzzer



Surface housing (accessory)



Surface housing (triple) for 2 beacons and 1 audible element (not included in assembly)

① TECHNICAL SPECIFICATIONS/ORDER SPECIFICATIONS:			
Dimensions (Ø x Height):	52 mm x 35 mm (Protrusion from panel)		
Housing:	PC/ABS-Blend; Cap: PC		
Tone frequency:	c. 2,100 Hz		
Tone type:	Continuous tone or pulse tone with approx. 1 Hz		
Fixing:	Installation mounting for Ø 22.5 mm (M22) with anti-twist device		
Connection:	Connector plug with screw terminal max. 1.5 mm ²		
Life duration:	> 5,000 hrs		
Voltage:	24 V AC/DC	115 V AC/DC	230 V AC
Current consumption:	25 mA	25 mA	25 mA
Continuous tone	109 000 75	109 000 77	109 000 68
Pulse tone	109 010 75	109 010 77	109 010 68

✂ ACCESSORIES:	
Bracket with protective cap (IP54), only 24 V	975 109 01 (see picture on page 193)
Single surface housing	975 109 02
Double surface housing	975 109 03
Triple surface housing	975 109 04
Assembly comprises of only the surface housing. Beacons 800-802 or 815-817 have to be ordered additionally.	

↔ TECHNICAL DIAGRAM:

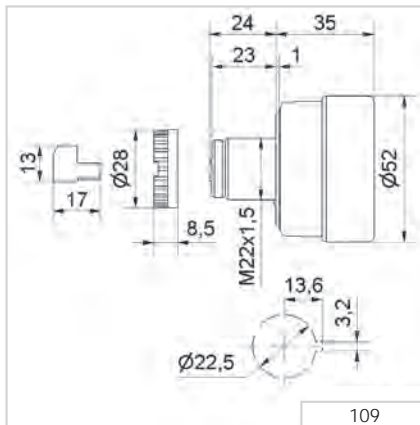

Signalisation index		
Continuous tone		3
Pulse tone		4



110 Electronic Installation Multi-Tone Sounder



Surface housing (accessory)



Bracket (accessory)

① TECHNICAL SPECIFICATIONS/ORDER SPECIFICATIONS:

Dimensions (Ø x Height):	72 mm x 40 mm (Protrusion from panel)		
Housing:	PC/ABS-Blend; Cap: PC		
Sound output:	Max. 100 dB (sound output is adjustable on rear side when mounted)		
Fixing:	Installation mounting for Ø 22.5 mm (M22) with anti-twist device		
Connection:	Connector plug with screw terminal max. 1.5 mm ²		
Life duration:	> 5,000 hrs		
Voltage:	24 V AC/DC	115 V AC	230 V AC
Current consumption:	80 mA	40 mA	40 mA
Order No.:	110 000 75	110 000 67	110 000 68

♫ TONE TYPES AND FREQUENCIES:

8 tones selectable on rear side of the housing

🎵 position 0		1.6 kHz	86 dB (A)
🎵 position 1		1.6 kHz	86 dB (A)
🎵 position 2		1.6 kHz	86 dB (A)
🎵 position 3		1.6 kHz	88 dB (A)
🎵 position 4		3.4 kHz	90 dB (A)
🎵 position 5		3.4 kHz	100 dB (A)
🎵 position 6		3.4 kHz	96 dB (A)
🎵 position 7		3.4 kHz	100 dB (A)

🔧 ACCESSORIES:

Bracket with protective cap (IP 54)	975 109 01
Surface housing IP 65 (single)	975 109 02
Surface housing IP 65 (double) for 1 installation beacon and 1 Installation siren	975 109 03
Surface housing IP 65 (triple) for 2 installation beacons and 1 Installation siren	975 109 04

↔ TECHNICAL DIAGRAM:

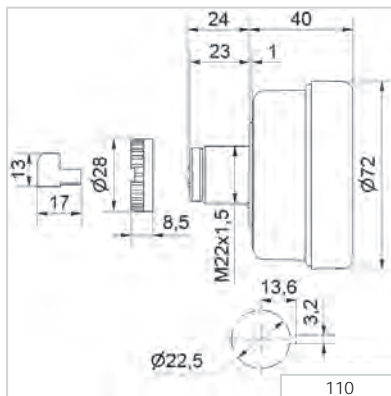

Signalisation index

Multi-tone sounder 5



111 Electronic Installation buzzer



With its minimum level of protrusion the installation buzzer 111 is ideal for control panel applications



Simple installation with single hole mounting for M22

① TECHNICAL SPECIFICATIONS/ORDER SPECIFICATIONS:

Dimensions (Ø x Height):	50 mm x 22 mm (Protrusion from panel)	
Housing:	PC/ABS-Blend, black; Cap: PC	
Tone frequency:	c. 2,800 Hz	
Tone type:	Continuous or pulse tone	
Fixing:	Installation mounting for Ø 22,5 mm (M22 x 1,5 mm)	
Connection:	Connector plug with screw terminal max. 1,5 mm ²	
Life duration:	> 5,000 hrs	
Assembly:	Nut and seal included in assembly	
Voltage:	24 V DC	230 V AC
Current consumption:	25 mA	20 mA
Continuous tone	111 000 55	111 000 68

↔ TECHNICAL DIAGRAM:

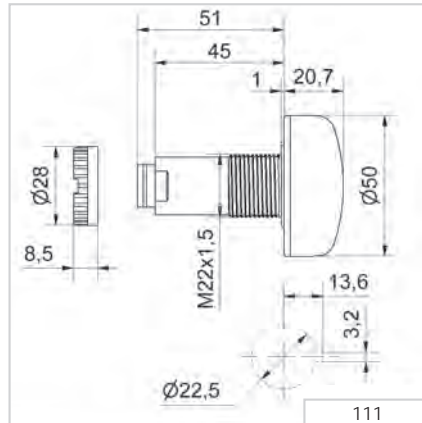

Signalisation index		
Continuous tone		3
Pulse tone		4

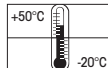

338 AC Installation Buzzer



338 373



338 323



① TECHNICAL SPECIFICATIONS/ORDER SPECIFICATIONS:

Dimensions (L x H x W):	23 mm x 18.5 mm x 35 mm (338 273)	
Material:	PC/ABS-Blend, black; Cover: PC	
Mounting:	As required	
Fixing:	M3 or M4 thread	
230 V AC, c. 65 dB, spades, fixing: M3		338 273 28
230 V AC, c. 75 dB, solder lugs for printed circuits, fixing: M3		338 323 28
230 V AC, c. 75 dB, spades, 6.3 x 0.8 mm, fixing: M3		338 373 28
230 V AC, c. 75 dB, spades, 6.3 x 0.8 mm, fixing: M4		338 374 28
Further voltages on request.		

↔ TECHNICAL DIAGRAM:

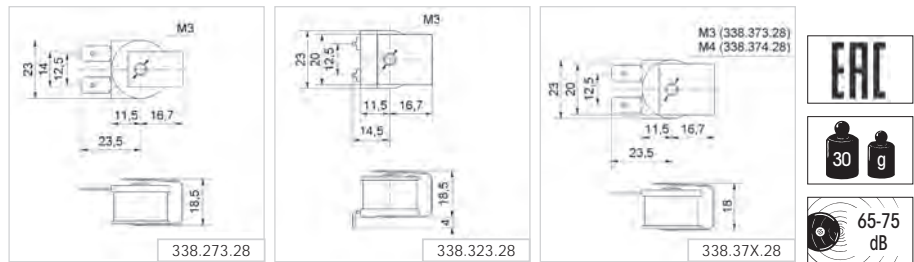

382 Installation Buzzer

① TECHNICAL SPECIFICATIONS/ORDER SPECIFICATIONS:

Dimensions (Ø x Height):	54.5 mm x 36.5 mm	
Housing:	Steel, passivated	
Connection:	AC: 2 wires, 215 mm long; DC: 2 wires, 50 mm long	
Fixing:	M3 thread	
AC Version		
Voltage:	230 V AC	
Current consumption:	15 mA	
Order No.:	382 013 68	
DC Version		
Voltage:	6 V DC	24 V DC
Current consumption:	100 mA	70 mA
Order No.:	382 013 53	382 013 55

↔ TECHNICAL DIAGRAM:

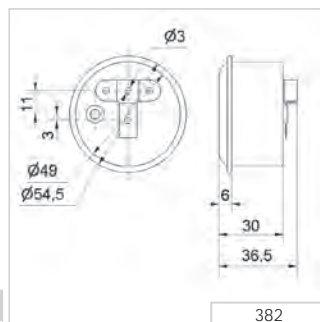

Signalisation index

338 Continuous tone	█	1
338 Pulse tone	█	1
382 Continuous tone	█	4





114 Electronic Installation Buzzer

① TECHNICAL SPECIFICATIONS/ORDER SPECIFICATIONS:

Dimensions (Ø x Height):	42.5 mm x 10 mm (Protrusion from panel)	
Housing:	PC/ABS-Blend; Nut: PA fibreglass, high-impact	
Connection:	Spades 6.3 x 0.8 mm, finger proof model according to BGV A2, when used with insulated spades	
Tone frequency:	c. 2,400 Hz	
Fixing:	Installation mounting for Ø 30.5 mm (M30)	
Voltage:	24 V DC (12-30 V)	230 V AC (110-240 V)
Current consumption:	20 mA	20 mA
Order No.:	114 068 15	114 068 28

↔ TECHNICAL DIAGRAM:

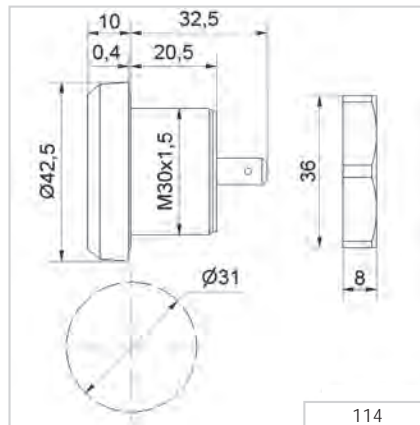

Signalisation index

Dauerton

3

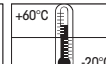

118/119 Electronic Installation Buzzer



Cap

① TECHNICAL SPECIFICATIONS/ORDER SPECIFICATIONS:

Dimensions (Ø x Height):	43 mm x 49 mm (Protrusion from panel)				
Housing:	PC/ABS-Blend				
Connection:	Spades 6.3 x 0.8 mm, finger proof model according to BGV A2, when used with insulated spades				
Tone frequency:	c. 2,400 Hz				
Tone type:	Type 118 Continuous tone Type 119 Continuous tone and pulse tone, c. 1 Hz, selectable via plug-in terminal Version with 3 tones: 2.7 kHz, 270 Hz, 337 Hz				
Fixing:	Installation mounting for Ø 28.5 mm (M28)				
Voltage:	12 V DC	24 V AC/DC	48 V AC/DC	115 V AC/DC	230 V AC
Current consumption:	20 mA	20 mA	20 mA	20 mA	20 mA
Continuous tone	118 068 14	118 068 15	118 068 26	118 068 27	118 068 28
Continuous/pulse tone	-	119 068 15	119 068 26	119 068 27	119 068 28
Voltage:	24 V DC (9-29 V DC)				
Current consumption:	< 30 mA (Tone 1)				
3 tones		119 004 55			

✂ ACCESSORIES:

Cap	975 118 00
-----	-------------------

↔ TECHNICAL DIAGRAM:

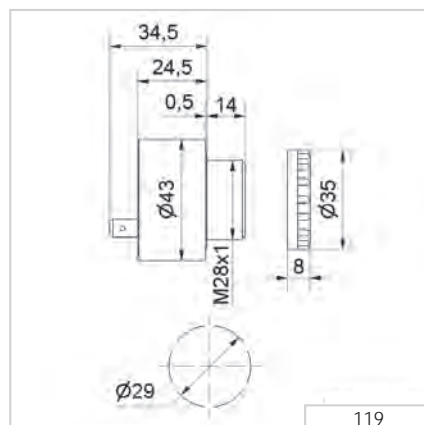
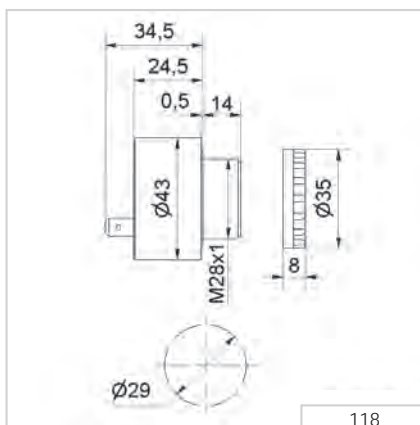

Signalisation index

Dauerton	4
Pulston	4



EvoSIGNAL - Horns & Sirens

Your benefits

The type of audible signals used depends on the application and the environment. With EvoSIGNAL, finding the right signal device has never been so easy: almost all applications are covered by only two sizes with specific mounting adapters. The new modular, simple and clear standard solution. EvoSIGNAL is one of a kind.

- Simple and easy to use: Number of different articles reduced to 20% whilst retaining a full range
- Adaptable: Adjustable volume, 10 tones available with Midi range
- Poka Yoke: Simple and intuitive installation - incorrect installation is impossible

Typical applications

Signal faults and statuses on machines and equipment, in building services engineering and for electric gates and entry access systems. All products are ideal for demanding indoor and outdoor applications.

- Mini – in installation sites with limited space
- Midi – signalling over medium distances (10–30 m)

Installation options

- Base mounting
- M22/PG 29 single-hole mounting
- Tube mounting
- Bracket mounting

Features

- Push fit connection terminals: Simple and permanently secure connection
- Fully compatible: Easy replacement of previous products
- Best-in-class equipment: Powerful, extremely robust (IP66), tamper-proof

Signalisation index	
Mini	5-6
Midi	7-8



Mini

Midi



EvoSIGNAL Mini - Horns & Sirens

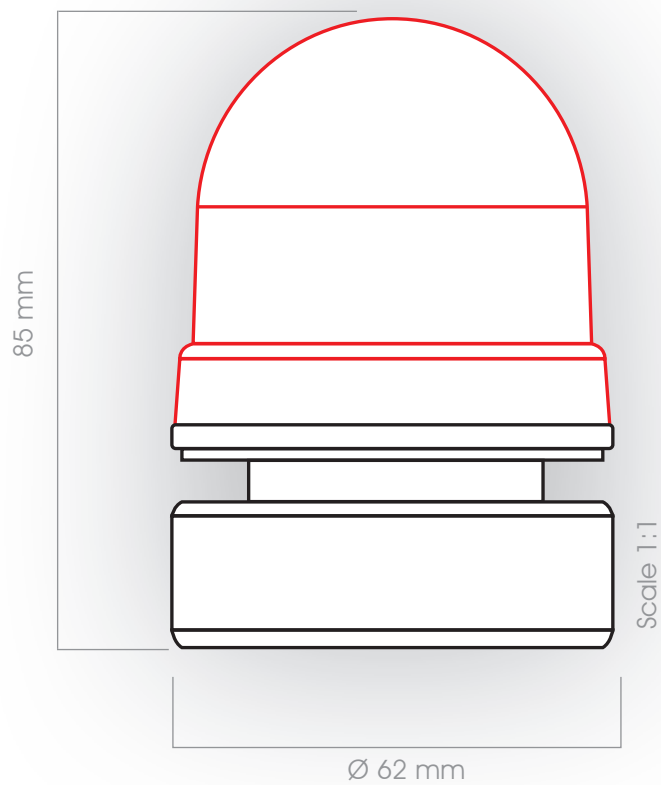

3
Horns & Sirens



6
Mounting adapter



EvoSIGNAL Mini - Horns & Sirens

OLD

Electronic buzzer	Horn
127	582
128	482



NEW



Quick-Finder Evo*SIGNAL* Mini - Horns & Sirens



12 V AC/DC

160 700 74

24 V AC/DC

160 700 75

115-230 V AC

160 700 60

+ Mounting adapter (compulsory!)

Base mounting



Order no.
260 700 01

Installation mounting M22



Order no.
260 700 03

Installation mounting PG 29



Order no.
260 700 04

Tube mounting



Order no.
260 700 05

Bracket mounting with cable gland

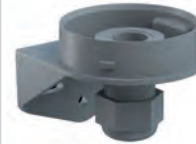

Order no.
260 700 06

Bracket mounting



Order no.
260 700 07

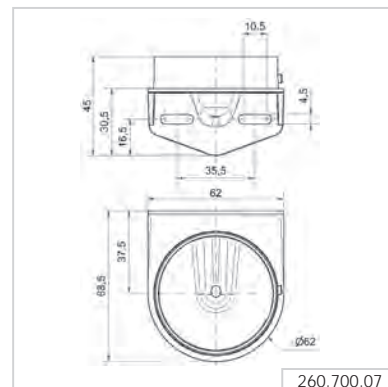
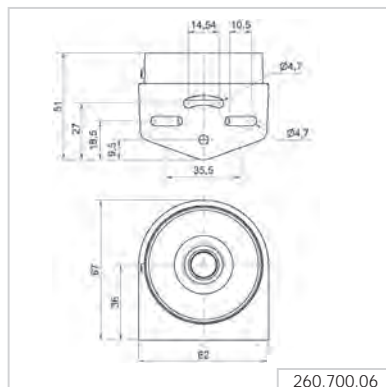
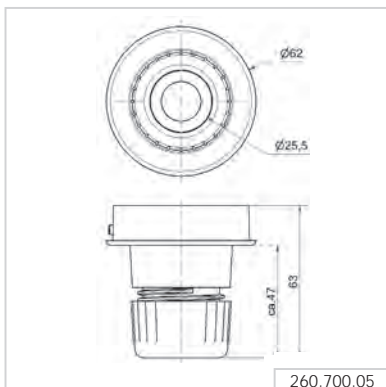
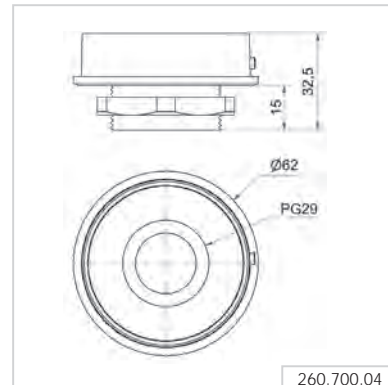
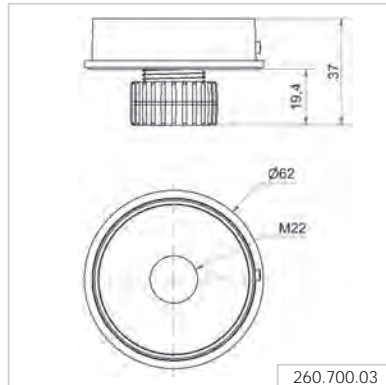
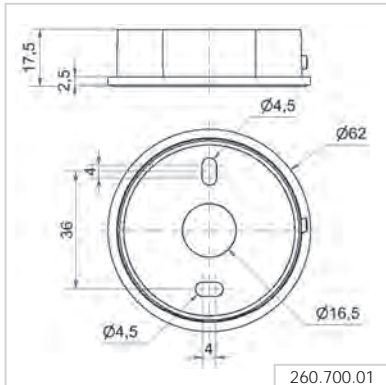



Bracket mounting with cable gland

EvoSIGNAL Mini - Horns & Sirens

① TECHNICAL SPECIFICATIONS/ORDER SPECIFICATIONS:

Dimensions (Ø x Height):	62 mm x 85 mm		
Housing:	PC/ABS		
Lens:	PC, grey		
Fixing:	Base/Tube/Wall and Inatallation mounting		
Cable entry:	Cable diameter 8-12 mm		
Connection:	Push-In terminal max. 1.5 mm ²		
Tone type:	Pulse or Permanent tone		
Voltage:	12 V AC/DC	24 V AC/DC	115-230 V AC
Current consumption:	≤ 30 mA	≤ 40 mA	≤ 30 mA
Order no.	160 700 74	160 700 75	160 700 60

✂ ACCESSORIES:

Base mounting	260 700 01
Installation mounting M22	260 700 03
Installation mounting PG 29	260 700 04
Tube mounting	260 700 05
Bracket mounting with cable gland	260 700 06
Bracket mounting	260 700 07

↔ TECHNICAL DIAGRAM:

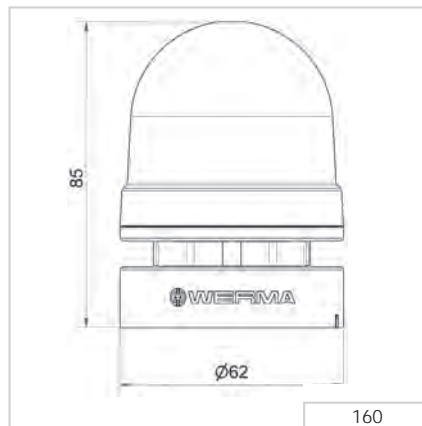

160

260.700.01

260.700.03

260.700.04

260.700.05
260.700.06

260.700.07

Signalisation index	
Permanent	5
Pulse	6

EvoSIGNAL Midi - Horns & Sirens

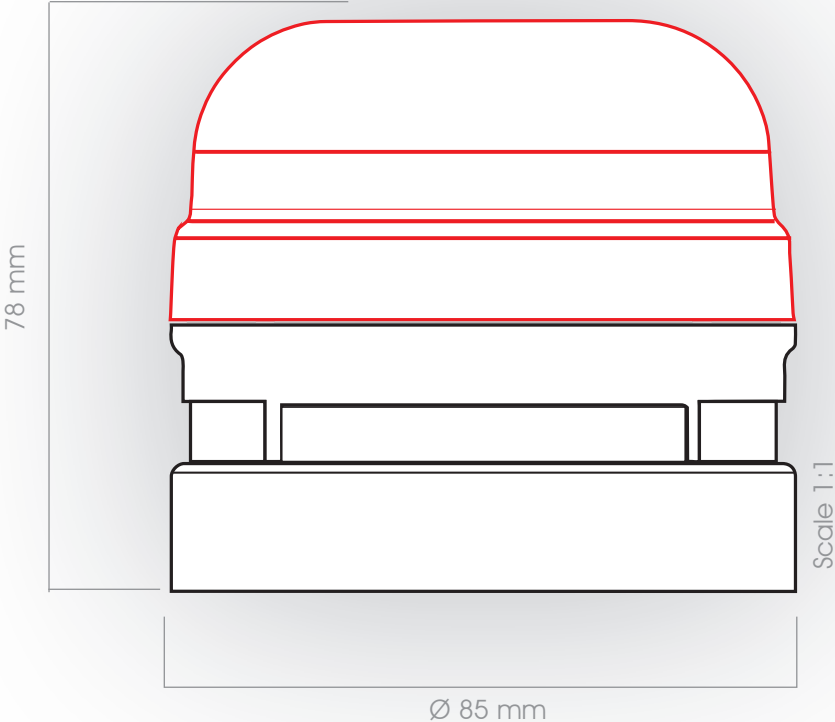

2
Horns & Sirens



6
Mounting adapter

EvoSIGNAL Midi - Horns & Sirens

OLD

Electronic Multi-Tone sounder	Electronic Horn
133	585
134	584



NEW



Quick-Finder EvoSIGNAL Midi - Horns & Sirens



12/24 V AC/DC

161 700 70

115-230 V AC

161 700 60

+ Mounting adapter (compulsory!)

Base mounting



Order no.
261 700 01

Base mounting
with cable gland



Order no.
261 700 02

Tube mounting



Order no.
261 700 05

Bracket mounting
with cable gland



Order no.
261 700 06

Bracket mounting



Order no.
261 700 07

Horn



Order no.
261 700 03

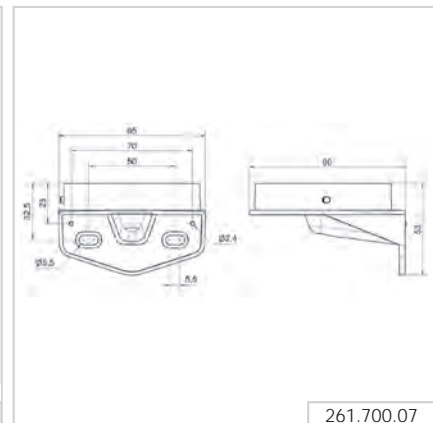
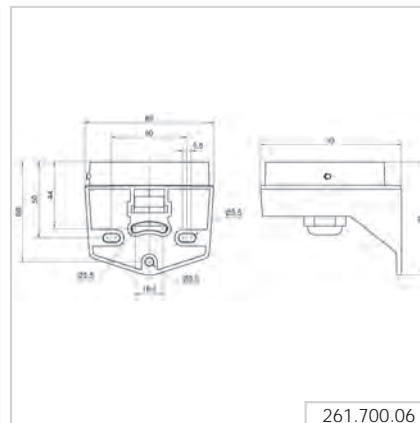
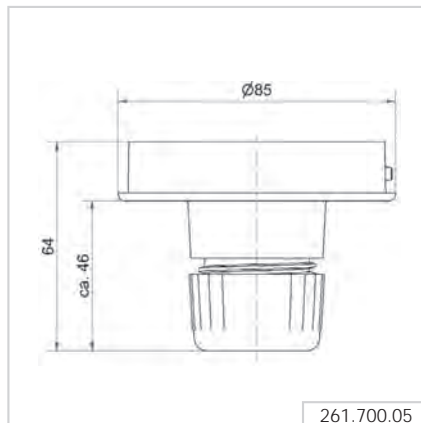
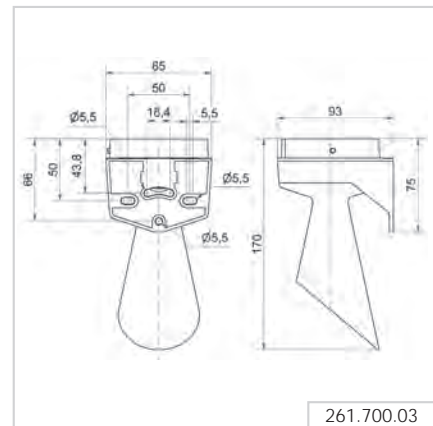
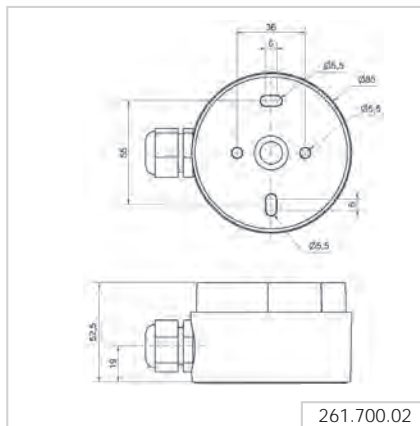
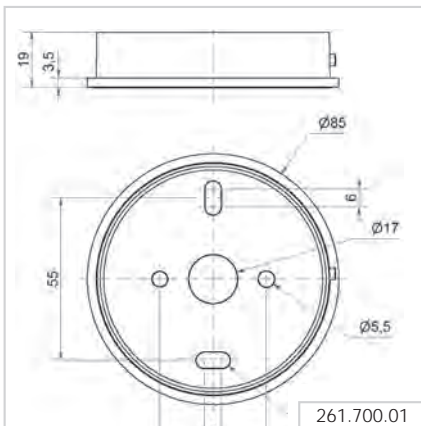

EvoSIGNAL Midi - Horns & Sirens



Base mounting



Tube mounting

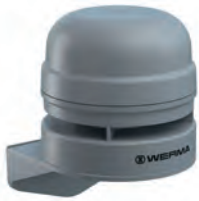

Bracket mounting

① TECHNICAL SPECIFICATIONS/ORDER SPECIFICATIONS

Dimensions (Ø x Height): 85 mm x 78 mm		
Housing:	PC/ABS	
Lens:	PC, grey	
Fixing:	Base/Tube/Wall mounting	
Cable entry:	Cable diameter 8-12 mm	
Connection:	Pusch-In terminal max. 1.5 mm ²	
Tone type:	Multi-tone	
Tone frequency:	3300 Hz	
<hr/>		
Voltage:	12/24 V AC/DC	115-230 V AC
Current consumption:	≤ 175 mA	≤ 105 mA
Order no.	161 700 70	161 700 60

♪ TONE TYPES AND FREQUENCIES

10 selectable tones and adjustable sound output

Tone	Tone type
0	Horn tone (ca. 110 Hz), max. 107 dB(A)
1	Continuous tone (ca. 3.3 kHz), max. 106 dB(A)
2	Pulse tone 1 Hz (ca. 3.3 kHz), max. 110 dB(A)
3	Whistle tone 20 Hz (ca. 3.3 kHz), max. 110 dB(A)
4	800 – 970 Hz rising @ 1 Hz, max. 95 dB(A)
5	2400 - 2850 Hz rising @ 7 Hz, max. 99 dB(A)
6	1200 – 500 Hz falling @ 1 Hz, max. 101 dB(A)
7	Alternating tone 800 Hz / 1200 Hz @ 1 Hz, max. 100 dB(A)
8	Sweep-Tone 2100 – 4100 Hz @ 0.5 Hz, max. 110 dB(A)
9	Continuous tone (c. 700 Hz), max. 97 dB(A)

✂ ACCESSORIES:

Base mounting	261 700 01
Base mounting with cable gland	261 700 02
Tube mounting	261 700 05
Bracket mounting	261 700 07
Bracket mounting with cable gland	261 700 06
Horn	261 700 03

↔ TECHNICAL DIAGRAM

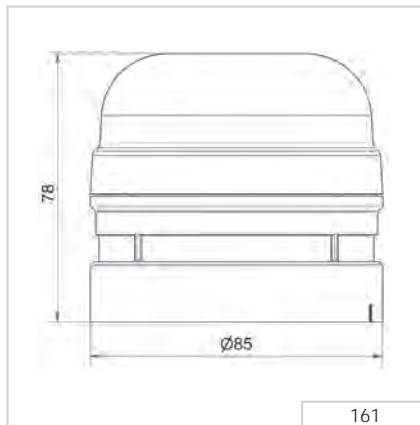

261.700.02

261.700.05

261.700.06

161

261.700.07

261.700.01

261.700.03

IP66

+60°C
-30°C

110 dB

Signalisation index	
Midi	8

Horns and Sirens

Your benefits

The loud Horns, Sounders and Sirens from WERMA provide safety and security by delivering reliable audible warning when faults occur over longer distances or in noisy environments.

- Quick and easy installation
- Tamper-proof when installed
- Ideal for noisy environments

Typical applications

Fault signalling

- On machine controllers and on large equipment
- In building service systems (e.g. gas alarm)
- Alarm in the event of overload (e.g. mobile cranes)

Installation options

- Wall mounting

Features

- 574/575 series with ten times longer life duration compared to electromechanical versions
- Up to 8 tones for signalling different statuses

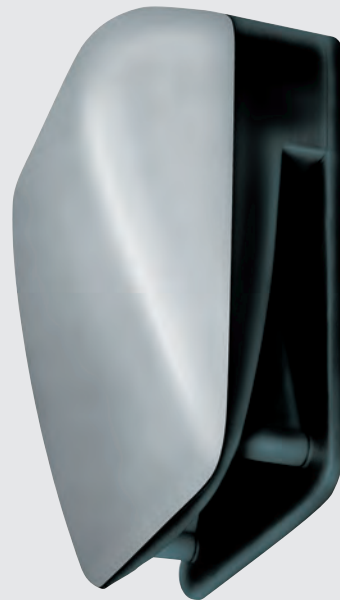

Signalisation index			
	126	574 + 575	570
Signal Horn		7	6
Multi-Tone Sounder	7		
	123	573	
Signal Horn		6	
Alternating Tone	7		





123 Electronic Siren



① TECHNICAL SPECIFICATIONS/ORDER SPECIFICATIONS:

Dimensions (L x H x W):	54 mm x 67 mm x 67 mm	
Housing:	ABS	
Tone frequency:	2.5 / 3.5 Hz	
Tone type:	Alternating	
Connection:	2 wires, c. 450 mm long	
Fixing:	Metal bracket	
Voltage:	12 V DC	24 V DC
Current consumption:	100 mA	100 mA
Order No.:	123 100 54	123 200 55

↔ TECHNICAL DIAGRAM:

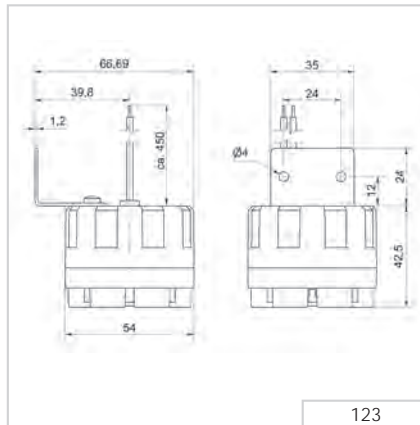

123

Signalisation index

Alternating tone 7

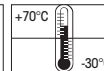

126 Electronic Multi-Tone Sounder



① TECHNICAL SPECIFICATIONS/ORDER SPECIFICATIONS:

Dimensions (L x H x W):	70 mm x 79.5 mm x 77 mm
Housing:	PC/ABS-Blend
Tone types and frequencies:	4 selectable tones adjustable Continuous tone: c. 2,700 Hz Continuous tone: c. 530 Hz Bell: c. 2,700 Hz (pulse 20 Hz) Pulse tone: c. 2,700 Hz (pulse 1 Hz)
Connection:	Screw terminal 0.5 - 1.5 mm ²
Cable entry:	Cable diameter max. 9 mm
Fixing:	Wall mounting, Sound outlet facing downwards
Voltage:	12-24 V DC
Current consumption:	80 mA
Order No.:	126 052 15

↔ TECHNICAL DIAGRAM:

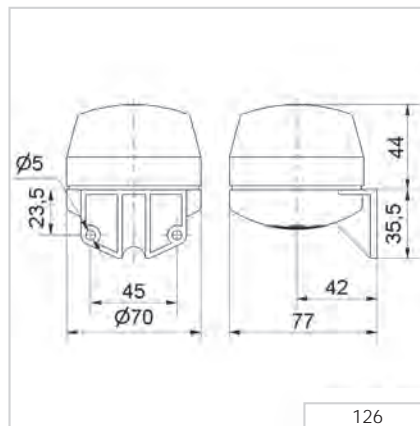

Signalisation index

Multi-tone sounder 7

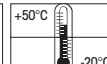

570 Electromechanical Signal Horn



① TECHNICAL SPECIFICATIONS/ORDER SPECIFICATIONS:

Dimensions (L x H x W):	148 mm x 350 mm x 152 mm			
Housing:	PC/ABS-Blend			
Connection:	Screw terminal 0.5 - 2.5 mm ²			
Fixing:	Wall mounting, Sound outlet facing downwards			
Voltage:	24 V AC (50 Hz)	42-48 V AC (50/60 Hz)	115 V AC (50/60 Hz)	230 V AC (50 Hz)
Current consumpt.:	500 mA	250 mA	200 mA	70 mA
Order No.:	570 052 65	570 052 66	570 052 67	570 052 68
Pulse tone (AC)				
Voltage:				230 V AC (50 Hz)
Current consumpt.:				≤ 70 mA
Order No.:				570 100 68
Continuous tone (DC)				
Voltage:	24 V DC		115 V DC	230 V DC
Current consumpt.:	350 mA		150 mA	100 mA
Order No.:	570 052 55		570 052 57	570 052 58
Further voltages on request.				

↔ TECHNICAL DIAGRAM:

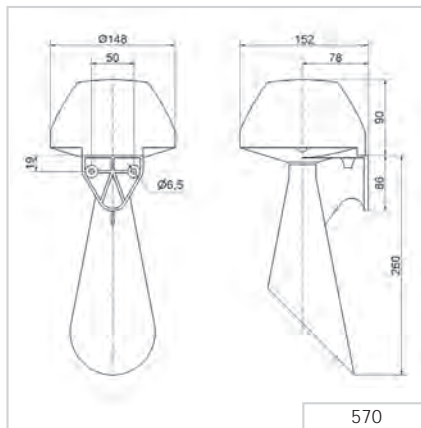

Signalisation index

Hupe 6

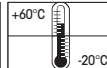

573 Electromechanical Signal Horn



① TECHNICAL SPECIFICATIONS/ORDER SPECIFICATIONS:

Dimensions (L x H x W):	104 mm x 232 mm x 232 mm				
Fixing dimensions (B x H):	130 mm x 160 mm				
Housing:	PC/ABS-Blend				
Connection:	Screw terminal 0.5 - 2.5 mm ²				
Cable entry:	Cable gland M16 x 1.5 mm Cable diameter 5-10 mm				
Fixing:	Wall mounting, Sound outlet facing downwards				
Voltage:	24 V DC	24 V AC (50 Hz)	42-48 V AC (50/60 Hz)	115 V AC (50/60 Hz)	230 V AC (50 Hz)
Current consumption:	350 mA	500 mA	250 mA	200 mA	70 mA
Order No.:	573 000 55	573 000 65	573 000 66	573 000 67	573 000 68

↔ TECHNICAL DIAGRAM:

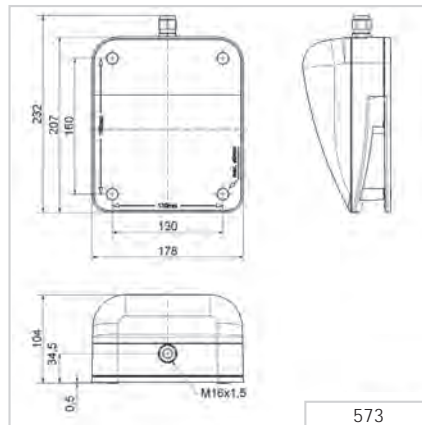

Signalisation index

Horn 6

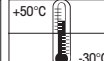



574 Electronic Signal Horn



① TECHNICAL SPECIFICATIONS/ORDER SPECIFICATIONS:

Dimensions (Ø x Height):	134 mm x 340 mm		
Housing:	PC/ABS-Blend, grey		
Fixing:	Wall mounting, integrated mounting bracket		
Installation position:	Sound outlet facing downwards		
Connection:	Screw terminal 0.5 - 1.5 mm ²		
Cable entry:	Cable diameter max. 11 mm		
Tone frequency:	C. 110 Hz		
Life duration:	Up to 5,000 hrs		
Voltage:	24 V AC/DC	10-48 V AC/DC*	115-230 V AC
Current consumption:	55 mA	210 mA	30 mA
Order No.:	574 000 75	574 000 70	574 000 60

* Current consumption at 10 V / 115 V

↔ TECHNICAL DIAGRAM:

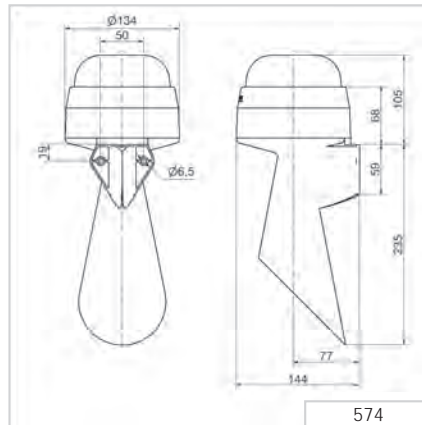

Signalisation index

Horn 7

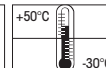

adjustable



575 Electronic Signal Horn



Quick and simple wall mounting without additional accessories with the integrated mounting bracket



① TECHNICAL SPECIFICATIONS/ORDER SPECIFICATIONS:

Dimensions (L x H x W):	134 mm x 169 mm x 144 mm		
Housing:	PC/ABS-Blend, grey		
Fixing:	Wall mounting, integrated mounting bracket		
Installation position:	Sound outlet facing downwards		
Connection:	Screw terminal 0.5 - 1.5 mm ²		
Cable entry:	Cable diameter max. 11 mm		
Tone frequency:	C, 110 Hz		
Life duration:	Up to 5,000 hrs		
Voltage:	24 V AC/DC	10-48 V AC/DC*	115-230 V AC
Current consumption:	55 mA	210 mA	30 mA
Order No.:	575 000 75	575 000 70	575 000 60

* Current consumption at 10 V / 115 V

↔ TECHNICAL DIAGRAM:

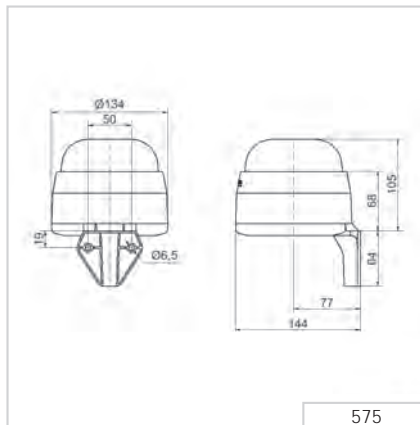

Signalisation index

Horn

7

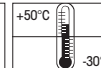

adjustable



Design Multi-Tone Sounder

Your benefits

WERMA Design Multi-Tone Sounders provide safety and security by providing an audible warning in applications with greater aesthetic requirements. The innovative housing design makes for simple mounting in many diverse applications.

- Ideal signalling effect over great distances
- Many application options with up to 32 tones available
- Up to 3 tones can be externally triggered for the escalation of signals
- Includes standardised tones (including those used in fire alarms)

Typical applications

- Signalling faults or alarms in the event of danger
- in building service systems
- on machinery and equipment

Installation options

- Wall mounting
- Base mounting
- Ceiling mounting

Features

- Up to 32 tones (standardised according to various standards and guidelines)
- Multi-voltage versions allow multiple applications with a single device



Signalisation index	
Audible	
Multi-Tone Sounder	8



140 Multi-Tone Sounder



① TECHNICAL SPECIFICATIONS/ORDER SPECIFICATIONS:

Dimensions (Ø x Height):	100 mm x 110 mm
Housing:	PC/ABS-Blend
Connection:	Screw terminal max. 2.5 mm ²
Cable entry:	Cable gland M20 x 1.5 mm Cable gland not included in assembly
Tone types and frequencies:	Selectable via DIP switch, see table page 186
Installation position:	Sound outlet not facing upwards
Voltage:	9-28 V DC
Current consumption:	≤ 120 mA
red	140 150 50
white	140 950 50
Voltage:	110-240 V AC
Current consumption:	≤ 40 mA
red	140 150 60
white	140 950 60

✂ ACCESSORIES:

Cable gland M20 x 1.5 mm	975 444 01
--------------------------	-------------------

↔ TECHNICAL DIAGRAM:

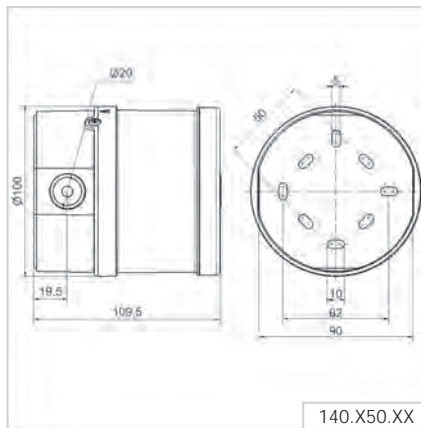

CE

Signalisation index

Multi-tone sounder 8



140 Tone table

The 140 Multi-Tone Sounder offers a large choice of internationally recognised signal tones for the widest spectrum of applications. The low voltage version allows two tones to be triggered externally. Selectable via DIP switch.

♪ TONE TYPES AND FREQUENCIES:

Tone 1 No.	Tone type	Description	Sound output (dBA)		Tone 2 Low voltage
			(12 V)	(24 V)	
1	alternating 800/970 Hz in 2 Hz stroke	BS 5839-1: 2002	101	105	14
2	rising 800/970 Hz in 7 Hz stroke		103	107	14
3	rising 800/970 Hz in 1 Hz stroke	BS 5839-1: 2002; VdS tested	104	108	14
4	continuous 2,850 Hz		110	115	14
5	rising 2,400-2,850 Hz in 7 Hz stroke		108	114	4
6	rising 2,400-2,850 Hz in 1 Hz stroke		109	115	4
7	500-1,200 Hz rising in 3 sec., 0.5 sec OFF		100	104	14
8	falling 1,200-500 Hz in 1 Hz stroke	DIN 33404; VdS tested	99	104	14
9	alternating 2,400/2,850 Hz in 2 Hz stroke		108	115	4
10	pulse 970 Hz in 0.5 Hz stroke	Back-up-alarm BS 5839 Part 1 1988	98	105	14
11	alternating 800/970 Hz in 1 Hz stroke	BS5839 Part 1 1988	100	105	14
12	pulse 2,850 Hz in 0.5 Hz stroke		107	114	4
13	970 Hz pulse: 0.25 sec. ON / 1 sec. OFF		96	105	14
14	continuous 970 Hz	BS 5839-1: 2002	101	105	15
15	554 Hz/100 ms alternating 440 Hz/400 ms	French alarm signal AFNOR NFS 32 S 32-001	97	102	14
16	660 Hz pulse: 150 ms ON, 150 ms OFF	Swedish alarm signal	97	101	17
17	660 Hz pulse: 1.8 sec. ON, 1.8 sec. OFF	Swedish alarm signal	97	103	16
18	660 Hz pulse: 6.5 sec. ON, 13 sec. OFF	Swedish alarm signal	99	103	14
19	continuous 660 Hz	Swedish alarm signal	99	103	21
20	alternating 554/440 Hz in 0.5 Hz stroke		99	103	21
21	pulse 660 Hz in 1 Hz stroke	Swedish alarm signal	98	104	19
22	2,850 Hz pulse: 150 ms ON, 100 ms OFF	Pedestrian crossing GB	109	115	14
23	rising 800/970 Hz in 50 Hz stroke	Low frequency BS 5839 Part 1 1988	101	106	14
24	rising 2,400-2,850 Hz in 50 Hz stroke	High frequency	106	112	4
25	970 Hz pulse: 3 x 500 ms ON, 500 ms OFF, Pause 1.5 sec.	ISO 8201 Low frequency: Evacuation	101	105	26
26	2,850 Hz pulse: 3 x 500 ms ON, 500 ms OFF, Pause 1.5 sec.	ISO 8201 High frequency	109	115	25
27	970/800 Hz alternating: 1.5 s ON, 0.5 s OFF		96	105	17
28	alternating 800/970 Hz in 2 Hz stroke	FP 1063.1 -Telecoms/BS 5839-1: 2002	99	105	10
29	alternating 988/645 Hz in 2 Hz stroke		99	104	988 Hz cont. tone
30	alternating 510/610 Hz in 2 Hz stroke		97	102	510 Hz cont. tone
31	falling 1,200-300 Hz in 1 Hz stroke		99	104	13
32	alternating 510/610 Hz in 1 Hz stroke		97	102	510 Hz cont. tone



144 Multi-Tone Sounder



Base Mounting



Wall mounting

① TECHNICAL SPECIFICATIONS/ORDER SPECIFICATIONS:			
Dimensions (L x H x W):	109 mm x 113 mm x 150 mm		
Housing:	PC/ABS-Blend		
Connection:	24 V: Screw terminal 0.5 - 1.5 mm ² 115/230 V: CAGE CLAMP®		
Cable entry:	Membrane for cable diameter max. 13 mm		
Fixing:	Wall, base and ceiling mounting		
Tone types and frequencies:	Selectable via DIP switch, see table on page 188		
Voltage:	24 V AC/DC	115 V AC	230 V AC
Current consumption:	200 mA	55 mA	30 mA
Order No.:	144 000 75	144 000 67	144 000 68

✂ ACCESSORIES:	
Cable gland M20 x 1.5 mm (for cable strain relief)	975 444 01
Protection rating IP 65 is provided even without cable gland	

↔ TECHNICAL DIAGRAM:

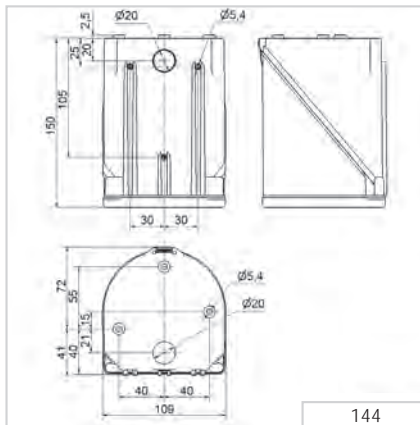

Signalisation index

Multi-tone sounder

8

24 V	115 V / 230 V			(A)	(C)	24 V
						PLC



144 Tone table

The 144 Multi-Tone Sounder offers a large choice of internationally recognised signal tones for the widest spectrum of applications. 3 tones can be triggered externally.

🎵 TONE TYPES AND FREQUENCIES:

Tone 1	Tone type	Frequency (Hz)	Description	Use	Tone 2	Tone 3	Output (dB)
1	continuous	200		BS 5839-1:2002	440 Hz cont.	554 Hz cont.	97
2	rising	800 & 970	7 Hz		14	800 Hz cont.	102
3	rising	800 & 970	1 Hz		14	800 Hz cont.	103
4	continuous	2850	3 s, then 0.5 s OFF (then repeat)		14	9	104
5	rising	2400 - 2850	7 Hz		4	2400 Hz cont.	109
6	rising	2400 - 2850	1 Hz		4	2400 Hz cont.	110
7	rising	500 - 1200	3 s, then 0.5 s OFF (then repeat)		14	8	106
8	falling	1200 - 500	1 Hz	DIN 33404-3	14	7	104
9	alternating	2400 & 2850	2 Hz		4	2400 Hz cont.	111
10	pulse	970	0.5 Hz (1 s On/1 s Off)	BS 5839 Part 1 1988	14	800 Hz cont.	101
11	alternating	800 & 970	1 Hz	BS 5839 Part 1 1988	14	800 Hz cont.	105
12	pulse	2850	0.5 Hz		4	22	104
13	pulse	970		0,25 s On/1 s Off	14	800 Hz cont.	98
14	continuous	970		BS 5839-1:2002 PFEER - Toxic gas	10	8	102
15	alternating	554 & 440		France NFS	14	800 Hz cont.	101
16	pulse	660	150 ms On/150 ms Off	Swedish	16	14	96
17	pulse	660	1.8 s On/1.8 s Off	Swedish	17	14	98
18	pulse	660	6.5 s On/13 s Off	Swedish	18	14	98
19	continuous	660		Swedish	19	31	98
20	alternating	554 & 440	0.5 Hz		20	19	102
21	pulse	660	1 Hz	Swedish	21	4	97
22	pulse	2850	150 ms On/100 ms Off	GB	14	4	104
23	rising	800 - 970	50 Hz (low)	BS 5839 Part 1 1988	14	800 Hz cont.	102
24	rising	2400 - 2850	50 Hz (high)		4	2400 Hz cont.	109
25	pulse	970	3 x 500 ms ON/500 ms OFF / 1.5 s silence, then repeat (low)	ISO 8201 US Temporal	26	14	101
26	pulse	2850	3 x 500 ms ON/500 ms OFF / 1.5 s silence, then repeat (high)	ISO 8201 US Temporal	25	4	104
27	continuous	4000			27	6	92
28	rising	2000 - 2850	7 Hz		2000 Hz cont.	4	111
29	alternating	988 & 645	2 Hz		988 Hz cont.	645 Hz cont.	102
30	alternating	510 & 610	2 Hz		510 Hz cont.	610 Hz cont.	102
31	alternating	800 & 970	2 Hz	5839-1:2002	800 cont.	14	105
32	alternating	800 & 1200	1 Hz		800 cont.	1200 Hz cont.	105



Vocal alarm

Your benefits

This extremely loud Vocal Alarm provides the ability to play application-specific audio files in order to produce clear and targeted instructions. It is particularly suitable for large assembly facilities and can address defined groups of people (for example, a particular work unit) in a targeted manner.

- Reliable alarm output over long distances or in noisy environments
- Easy to adjust to local conditions
- Excellent audio and sound quality for optimum clarity of signalling
- Completely flexible; select the audio file yourself

Typical applications

Signalling faults or issuing specific instructions

- For areas with high ambient noise levels
- In production and assembly environments

Installation options

- Wall mounting

Features

- Plays customer-specific audio files (sounds, melodies and your own recorded messages)
- 15 files can be played, or a sequence with a maximum of 50 files
- Simple USB data transfer
- Sound output can be externally triggered up to 110 dB



Signalisation index	
Audible	
Vocal alarm	7



154 Vocal alarm



Vocal alarm 154

① TECHNICAL SPECIFICATIONS/ORDER SPECIFICATIONS:	
Dimensions (L x H x W):	111 mm x 98 mm x 111 mm
Housing:	PP-GF, PC/ABS Blend
Sound output:	Adjustable, up to 110 dB
File Transfer:	Via USB connection and provided software
Possible data format:	mp3 and wav files
Number of sequences:	15 files can be remotely triggered or one sequence with max. 50 files
Suitable for:	Windows®, System requirements - see Handbook
Assembly:	Vocal alarm , USB connection cable and software
Voltage:	24 V DC
Current consumption:	< 500 mA Low Power < 1500 mA High Power
Order No.:	154 000 55

↔ TECHNICAL DIAGRAM:

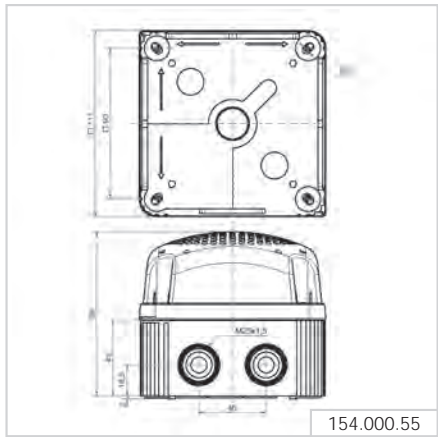

User-friendly software ensures easy transfer of audio files and simple operation

Signalisation index	
Vocal alarm	7

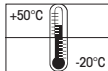

Heavy Duty Multi-Tone Sounder

Your benefits

The robust housings of WERMA Heavy Duty Multi-Tone Sounders are particularly well-suited for use in public areas or in harsh industrial environments. Versions with an aluminium housing and separate certification (German Lloyd) are available for marine applications.

- Ideal in extremely noisy environments and over long distances
- Many application options with up to 42 tones
- Up to 3 tones can be externally triggered for the escalation of signals
- Includes standardised tones (including those used in fire alarms)

Typical applications

Signalling of faults and alarms

- outdoors in extreme conditions
- in larger industrial plants
- in maritime applications

Installation options

- Wall mounting

Features

- High protection rating up to IP67
- Multi-voltage versions allow multiple applications with a single device



Signalisation index				
Audible	139	141	142	129
Multi-Tone Sounder	6	8	10	8





129 Electronic Multi-Tone Sounder (110 dB)



① TECHNICAL SPECIFICATIONS/ORDER SPECIFICATIONS:

Dimensions (L x H x W):	143 mm x 161 mm x 161 mm		
Housing:	Die-cast aluminium		
Connection:	Screw terminal 0.5 - 2.5 mm ²		
Cable entry:	Cable gland M20 x 1.5 mm Cable diameter 8-12 mm		
Tone types and frequencies:	Selectable via DIP switch, see table page 193		
Voltage:	24 V DC	115 V AC	230 V AC
Current consumption:	400 mA	120 mA	60 mA
Order No.:	129 052 55	129 052 67	129 052 68

↔ TECHNICAL DIAGRAM:

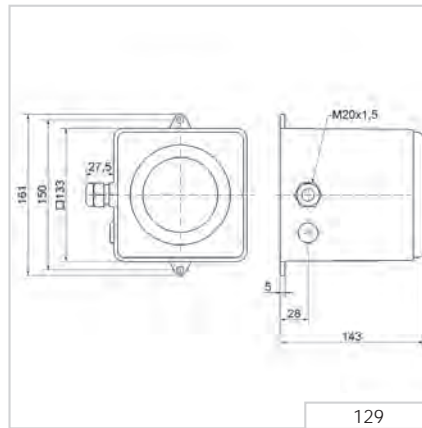

Signalisation index

Multi-tone sounder



24 V



230 V

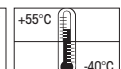

129 Tone table

The 129 Multi-Tone Sounder offers a large choice of internationally recognised signal tones for the widest spectrum of applications.

🎵 TONE TYPES AND FREQUENCIES:		
Tone 1+2 No.	Tone type	Description
1	falling 1,200-500 Hz in 1 Hz stroke	DIN 33404
2	950 Hz pulse: 3 x 500 ms ON, 500 ms OFF, Pause 1.5 sec.	ISO 8201
3	alternating 825 Hz/1,025 Hz in 2 Hz stroke	
4	continuous 950 Hz	
5	950 Hz pulse: 1 sec. ON, 1 sec. OFF	
6	500-1,200 Hz rising and falling in 3 sec.	Siren
7	554 Hz/100 ms alternating 440 Hz/400 ms	French fire alarm signal AFNOR NFS 32 S 32-001
8	pulse 700 Hz: 150 ms ON, 150 ms OFF, cycle 1 Min.	
9	pulse 800 Hz: 4 ms ON, 4 ms OFF	
10	continuous 500 Hz	
11	continuous 725 Hz	
12	continuous 825 Hz	
13	continuous 1,250 Hz	
14	continuous 1,500 Hz	
15	pulse 500 Hz: 500 ms ON, 500 ms OFF	
16	pulse 825 Hz: 500 ms ON, 500 ms OFF	
17	pulse 725 Hz: 0.7 sec. ON, 0.3 sec. OFF	
18	pulse 800 Hz: 0.25 sec. ON, 1 sec. OFF	
19	alternating 800 Hz/1,000 Hz in 2 Hz stroke	
20	pulse 825 Hz: 2.5 sec. ON, 2.5 sec OFF x 7, then 7 sec. pulse	
21	pulse 950 Hz: 1 sec. ON, 1 sec. OFF, 3 sec. ON, 1 sec. OFF	
22	rising 500-1,200 Hz in 3 sec., 0.5 sec OFF	
23	rising 500-2,400 Hz in 3 sec.	
24	alternating 825 Hz/1,075 Hz in 1 Hz stroke	
25	alternating 500 Hz/900 Hz in 2 Hz stroke	
26	alternating 1,200 Hz/1,400 Hz in 25 Hz stroke	
27	rising 300-1,200 Hz in 3 sec.	
28	700-1,500 Hz rising and falling in 3 sec.	
29	rising 150-1,000 Hz in 10 sec., 40 sec. ON, falling in 10 sec.	
30	pulse 680 Hz: 0.875 sec. ON, 0.875 sec. OFF	
31	rising 1,400-1,600 Hz in 1 sec., falling in 0.5 sec.	





139 Electronic Multi-Tone Sounder (105 dB)

① TECHNICAL SPECIFICATIONS/ORDER SPECIFICATIONS:

Dimensions (L x H x W):	136 mm x 108 mm x 119 mm	
Housing:	ABS	
Connection:	Screw terminal 0.5 - 2.5 mm ²	
Cable entry:	Cable gland M20 x 1.5 mm (not included in assembly)	
Tone types and frequencies:	Selectable via DIP switch	
Voltage:	9-60 V DC	115/230 V AC
Current consumption:	15 mA (24V)	20 mA (230 V)
red	139 000 55	139 000 68
grey	139 100 55	139 100 68

✂ ACCESSORIES:

Cable gland M20 x 1.5 mm	975 444 01
--------------------------	-------------------

♪ TONE TYPES AND FREQUENCIES:

For further details see www.werma.com.

↔ TECHNICAL DIAGRAM:

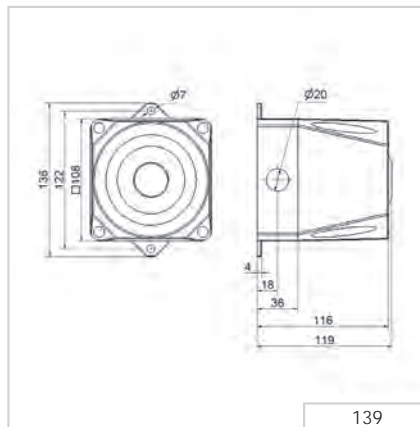

Signalisation index

Multi-tone sounder 6

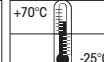

141 Electronic Multi-Tone Sounder (110 dB)



① TECHNICAL SPECIFICATIONS/ORDER SPECIFICATIONS:

Dimensions (L x H x W):	165 mm x 136 mm x 132 mm	
Housing:	PC/ABS-Blend	
Connection:	Screw terminal 0.5 - 2.5 mm ²	
Cable entry:	Cable gland M20 x 1.5 mm (not included in assembly)	
Tone types and frequencies:	Selectable via DIP switch	
Voltage:	9-60 V DC	115/230 V AC
Current consumption:	120 mA (24V)	22 mA (230 V)
red	141 000 55	141 000 68
grey	141 100 55	141 100 68

✂ ACCESSORIES:

Cable gland M20 x 1.5 mm	975 444 01
--------------------------	-------------------

♪ TONE TYPES AND FREQUENCIES:

For further details see www.werma.com.

↔ TECHNICAL DIAGRAM:

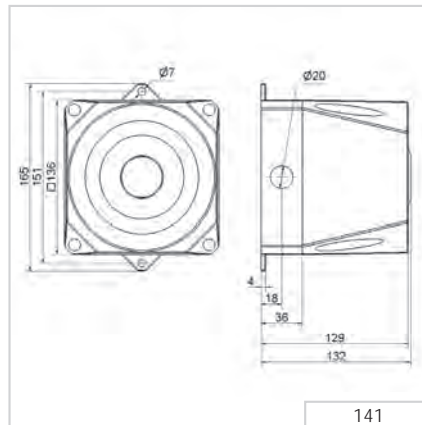

Signalisation index

Multi-tone sounder 8

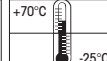

142 Electronic Multi-Tone Sounder (120 dB)



① TECHNICAL SPECIFICATIONS/ORDER SPECIFICATIONS:

Dimensions (L x H x W):	168 mm x 168 mm x 155 mm	
Housing:	PC/ABS-Blend	
Connection:	Screw terminal 0.5 - 2.5 mm ²	
Cable entry:	Cable gland M20 x 1.5 mm (not included in assembly)	
Tone types and frequencies:	Selectable via DIP switch, see table on page 197	
Voltage:	18-30 V DC	115/230 V AC
Current consumption:	450 mA	130 mA (115 V) / 65 mA (230 V)
red	142 000 55	142 000 68
grey	142 100 55	142 100 68

✂ ACCESSORIES:

Cable gland M20 x 1.5 mm	975 444 01
--------------------------	-------------------

↔ TECHNICAL DIAGRAM:

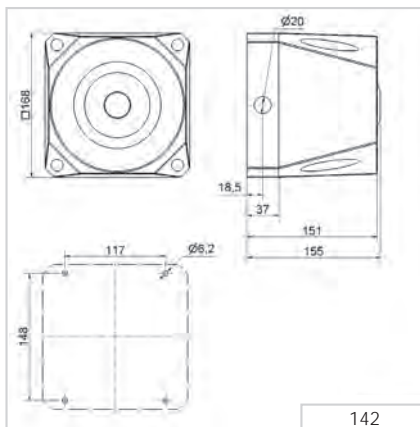

Signalisation index

Multi-tone sounder 10



142 X00 68



142 X00 55

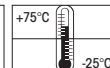

142 Tone table

The 142 Multi-Tone Sounder offers a large choice of internationally recognised signal tones for the widest spectrum of applications. The first two tones can be freely chosen. The third tone is paired with the second tone.

🎵 TONE TYPES AND FREQUENCIES:				
Tone 1+2 No.	Tone type	Description	Output (dBA)	Tone 3
1	alternating 800/970 Hz in 2 Hz stroke (250 ms-250 ms)		120	14
2	rising 800/970 Hz in 7 Hz stroke (7/s)		120	14
3	rising 800/970 Hz in 1 Hz stroke (1/s)		120	14
4	continuous 2,850 Hz		111	9
5	rising 2,400-2,850 Hz in 7 Hz stroke		109	4
6	rising 2,400-2,850 Hz in 1 Hz stroke		110	4
7	500-1,200 Hz rising in 3 sec., 0.5 sec. OFF	Slow Whoop Holland	119	14
8	falling 1,200-500 Hz in 1 Hz stroke	DIN/PFEER (PAPA), DIN 33404-3, VDS tested	119	14
9	alternating 2,400/2,850 Hz in 2 Hz stroke (250 ms-250 ms)		119	14
10	pulse 970 Hz in 0.5 Hz stroke (1 sec. ON / 1 sec. OFF)	PFEER Alarm	113	4
11	alternating 800/970 Hz in 1 Hz stroke (500 ms-500 ms)		117	14
12	pulse 2,850 Hz in 0.5 Hz stroke (1 sec. ON / 1 sec. OFF)		118	144
13	970 Hz pulse: 0.25 sec. ON / 1 sec. OFF		112	14
14	continuous 970 Hz	PFEER - Toxic gas	117	8
15	554 Hz/100 ms alternating 440 Hz/400 ms	French alarm signal AFNOR NFS 32 S 32-001	118	14
16	660 Hz pulse: 150 ms ON, 150 ms. OFF	Swedish alarm signal	115	14
17	660 Hz pulse: 1.8 sec. ON, 1.8 sec. OFF	Swedish alarm signal	114	14
18	660 Hz pulse: 6.5 sec. ON, 13 sec. OFF	Swedish alarm signal	115	14
19	continuous 660 Hz	Swedish alarm signal	116	1
20	alternating 554/440 Hz in 0.5 Hz stroke (1 sec. ON / 1 sec. OFF)	Swedish alarm signal	115	19
21	pulse 660 Hz in 1 Hz stroke (500 ms-500 ms)	Swedish alarm signal	115	4
22	pulse 2,850 Hz in 4 Hz stroke (150 ms ON / 100 ms OFF)		110	4
23	rising 800-970 Hz in 50 Hz stroke		117	14
24	rising 2,400-2,850 Hz in 50 Hz stroke		110	4
25	970 Hz pulse: 3 x 500 ms. ON, 500 ms OFF, break 1.5 sec.	ISO 8201 / US Temporal	118	14
26	2,850 Hz pulse: 3 x 500 ms. ON, 500 ms OFF, break 1.5 sec.	ISO 8201 / US Temporal	112	4
27	continuous 4,000 Hz		105	6
28	alternating 800/970 Hz in 2 Hz stroke (250 ms-250 ms)		118	14
29	alternating 990/650 Hz in 2 Hz stroke (250 ms-250 ms)		117	14
30	alternating 510/610 Hz in 2 Hz stroke (250 ms-250 ms)		116	14
31	rising 300-1,200 Hz in 1 Hz stroke		118	14
32	continuous Bell		117	3
33	continuous Bell: 3x500 ms. Pulse, 1.5 sec. Silence, then repeat	Bell / US Temporal	117	14
34	alternating 1,000/2,000 Hz in 1 Hz stroke (500 ms-500 ms)	Singapore	115	4
35	pulse 420 Hz (0,625 sec.)	Australian alarm signal	118	14
36	500-1,200 Hz rising in 3,75 sec., then 0,25 sec. OFF	Australian alarm signal (Evacuation)	117	14
37	rising 1,400-1,600 Hz in 1 sec., falling in 0.5 sec.	NF C 48-265	116	14
38	500-1,200 Hz rising and falling 3 sec.	Siren	117	14
39	pulse 720 Hz: 0.7 sec. ON, 0.3 sec. OFF	German industrial alarm	118	14
40	rising 422-775 Hz in 0.85 sec., 1 sec. silence, then repeat	NFPA Whoop	118	14
41	continuous 470 Hz	Horn (USA)	114	3
42	continuous 370 Hz	Air Horn (USA)	113	3





Alarm Bell

Your benefits

A signalling technology classic: The robust WERMA Alarm Bell for signalling break-time or machine activation warnings.

- Many application possibilities
- Robust housing prevents damage when used in public areas or in harsh industrial environments

Typical applications

As a bell or alarm

- Goods receiving areas
- Entry/exit applications
- Counter service call point, etc.

Installation options

- Wall mounting

Features

- High IP66 protection rating for outdoor use



Signalisation index	
Audible	
Alarm Bell	5

914 Alarm Bell



① TECHNICAL SPECIFICATIONS/ORDER SPECIFICATIONS:

Dimensions (Ø x Depth):	167 mm x 76 mm		
Housing:	Steel bell, epoxy powder coated		
Connection:	Screw terminal max. 1.5 mm ²		
Cable entry:	Cable gland M16 x 1.5 mm Cable diameter 5-10 mm		
Voltage:	24 V DC	110 V AC (50/60 Hz)	230 V AC
Current consumption:	300 mA	90 mA	55 mA
Order No.:	914 052 55	914 052 67	914 052 68 (50 Hz)

↔ TECHNICAL DIAGRAM:

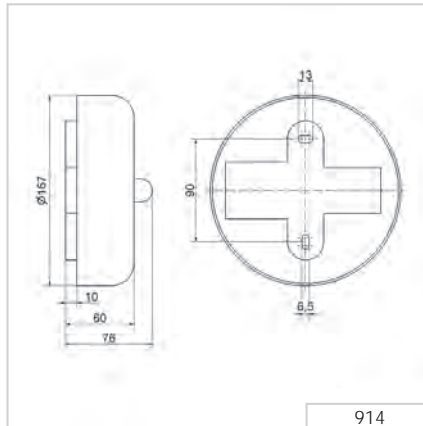

Signalisation index

Alarm bell 5

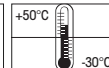

at DC - 98 dB(A)
at AC - 100 dB(A)

Ex Horns and Sirens

Your benefits

Ex Horns and Sirens from WERMA have been developed specifically for use in potentially explosive atmospheres. The Ex signalling devices are designed for use in explosive gas and vapour atmospheres (zones 1 and 2).

- Many years of proven use in potentially explosive areas
- Light and compact design for easy mounting
- Diverse signalling options

Typical applications

Signalling of faults or alarms

- during the processing or filling of highly flammable substances (gases and/or vapours and liquids)
- during storage of highly flammable substances (gases and/or vapours and liquids)
- in industrial plants with flammable dust atmospheres (e.g. metal processing, sawmills, mills, powdered milk processing plants)

Installation options

- Wall mounting

Features

- For use with or without the use of a safety barrier (depends on product)
- Proven technology with ATEX and IECEx certifications

761:

- „E“ terminal box for easy connection; approved for use in gas and dust applications (zones 1 and 21)



Signalisation index	
Audible	
Continuous Tcone	4
Signal Horn	6

718 Ex Electronic Installation Buzzer



Cap (accessory)



Zener Barrier (accessory)

① TECHNICAL SPECIFICATIONS/ORDER SPECIFICATIONS:

Dimensions (Ø x Height):	43 mm x 14 mm (Protrusion from panel)				
Housing:	PC/ABS-Blend				
Connection:	Spades 6.3 x 0.8 mm				
Tone frequency:	c. 2,400 Hz				
Duty cycle:	100 %				
Explosion protection:	Ex II 2G Ex ib IIC T4 / T5 / T6 Gb				
Approval:	DMT 98 ATEX E 005 X				
Maximum values of the Zener barrier:	Ui: 40 V DC, Ii: 660 mA				
Minimum values of the Zener barrier:	For 24 V DC 15 V DC/ 20 mA				
Maximum Input Power Pi:	Temp.- classes	Max. surrounding temperature			
		+ 40°C	+ 50°C	+ 60°C	
		T4	Pi = 1.3 W	Pi = 1.2 W	Pi = 1.0 W
		T5	Pi = 0.82 W	Pi = 0.66 W	Pi = 0.52 W
T6	Pi = 0.6 W	Pi = 0.45 W	Pi = 0.3 W		
Voltage:	24 V DC				
Current consumption:	20 mA				
Order No.:	718 000 55				

✳ ACCESSORIES:

PC/ABS-Blend Cap (IP 43)	975 118 00
Zener Barrier	975 714 01

↔ TECHNICAL DIAGRAM:

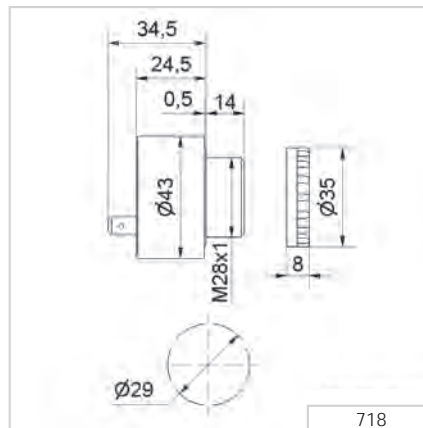

Signalisation index

Continuous tone 4

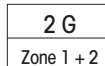

with cap

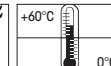



750 Ex Signal Horn

① TECHNICAL SPECIFICATIONS/ORDER SPECIFICATIONS:

Dimensions (L x H x W):	148 mm x 350 mm x 152 mm				
Housing:	PC/ABS-Blend				
Connection:	Cable 3 m, 2 x 0.75 mm ²				
Fixing:	Bracket mounting, sound outlet facing downwards				
Explosion protection:	Ⓔ II 2G Ex mb IIC T5 Gb				
Approval:	BVS 03 ATEX E 118X				
Voltage:	24 V DC	24 V AC	42-48 V AC	115 V AC	230 V AC
Voltage:	21.6 V ... 26.4 V	21.6 V ... 26.4 V	37.8 V ... 52.8 V	102.5 V ... 126.5 V (50 Hz)	108 V ... 131 V (60 Hz)
Current consumption:	350 mA	450 mA	220 mA	205 mA	70 mA
Order No.:	750 000 55	750 000 65	750 000 66	750 000 67	750 000 68

↔ TECHNICAL DIAGRAM:

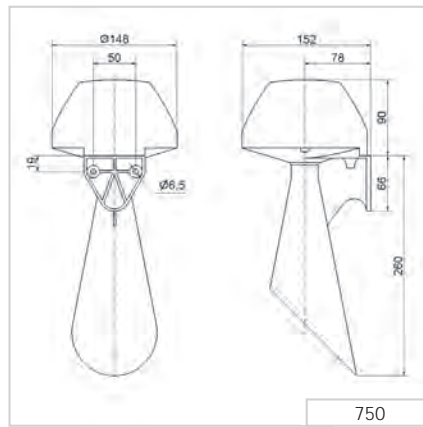

Signalisation index

Horn 6



2 G
Zone 1 + 2

1,3 kg



+50°C
-40°C

105 dB

761 Ex Signal Horn



① TECHNICAL SPECIFICATIONS/ORDER SPECIFICATIONS:

Dimensions (L x H x W):	178 mm x 232 mm x 104 mm					
Housing:	PC					
Connection:	CAGE CLAMP® max. 2.5 mm ²					
Cable entry:	Cable gland M16 x 1.5 mm; Cable diameter 6.5-9.5 mm					
Fixing:	Wall mounting, surface mounting					
Explosion protection:	Ⓔ Ex II 2G Ex e mb IIC T5 Gb Ⓔ Ex II 2D Ex tb IIIC T 70°C Db					
Approval:	BVS 03 ATEX E 118X					
Voltage:	24 V DC	24 V AC	48 V AC	115 V AC	230 V AC	
Voltage:	21.6 V ...	21.6 V ...	37.8 V ...	102.5 V ...	108 V ...	208 V ...
	26.4 V	26.4 V	52.8 V	126.5 V (50 Hz)	131 V (60 Hz)	250 V (50 Hz)
Current consumption:	350 mA	450 mA	220 mA	205 mA		70 mA
Order No.:	761 000 55	761 000 65	761 000 66	761 000 67	761 000 68	

↔ TECHNICAL DIAGRAM:

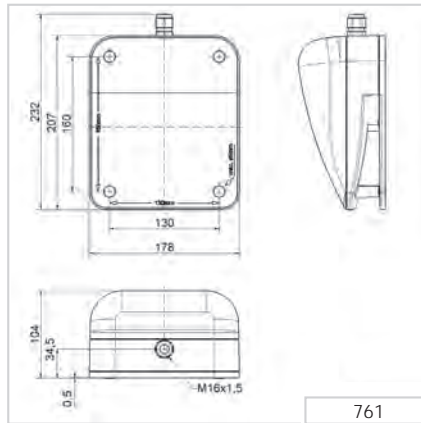

Signalisation index

Horn 6

