

# ULTRAPLUG®

## Enclosure Hole Plug Assemblies

AMHS Series

ULTRAPLUG® hole plugs are designed to plug and seal unused holes in metallic, aluminum and nonmetallic enclosures. They fit a wide range of sizes, so there is no need for restrictive hole-centering spacers. The self-centering, anti-rotational design insures quick and simple one-person nut assembly and no tools are required for tightening and maintaining a NEMA 4X enclosure rating. To learn more, visit [alliedmoulded.com](http://alliedmoulded.com).



### HOLE PLUG FEATURES

- Innovative plug "fins" have self-centering, anti-rotational design for fast and easy one-person plug assembly and no-tools tightening
- Plugs fit a wide range of hole sizes without the use of restrictive hole-centering spacers
- Patent pending design
- Recognized component for use with UL® and CSA® listed enclosure products
- Molded material of construction for a wide range of chemical compatible applications (polycarbonate with neoprene/EPDM gasket)
- Assembly designed to maintain applicable NEMA/UL/CSA enclosure ratings  
*\*Note: For use on flat surfaces of Type 1, 3R, 4, 4X and 12 enclosures*
- Designed for use with wall thicknesses from 16 gauge through 1/4"
- Designed for use with all metallic and nonmetallic enclosure materials
- Low profile interior nut and exterior plug saves valuable panel space
- Capable of sealing unused holes ranging in size from 1/2" to 4-3/4"

### SIMPLE INSTALLATION

1. Push and twist the plug into the hole, engaging the fins.
2. Screw in and tighten the nut until the plug bottoms out on the substrate. Hand tighten only.

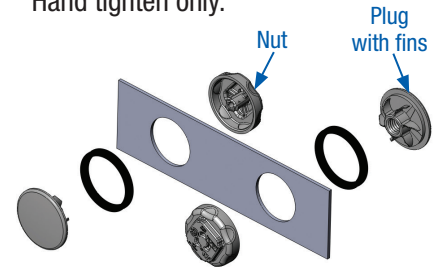

### CONTACT INFORMATION

Allied Moulded Products Inc.  
222 North Union Street  
Bryan, OH 43506 USA

Phone: 1-800-722-2679

Fax: 1-800-237-7269

Email: [sales@alliedmoulded.com](mailto:sales@alliedmoulded.com)



**ALLIED  
MOULDED  
PRODUCTS, Inc.**

Scan to watch  
the latest video!



[www.alliedmoulded.com](http://www.alliedmoulded.com)

# Hole Plug Assemblies

Allied Moulded's ULTRAPLUG® hole plug assemblies are for sealing unused holes in NEMA 4X enclosures made of many different substrates. They are available in two different colors to match your specific enclosure. The patent-pending design features one-person assembly for quick and easy installation.

## ULTRAPLUG®

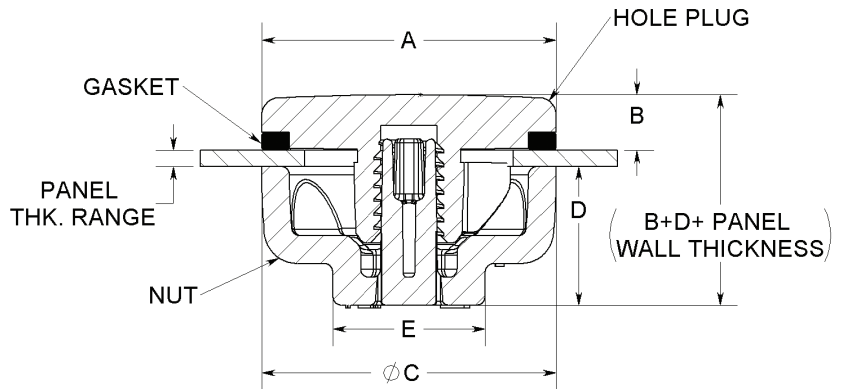
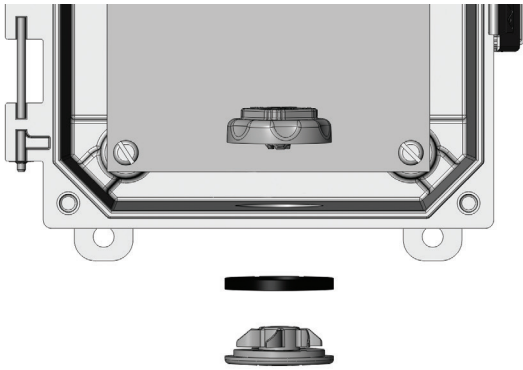

Note: For use on flat surfaces of Type 1, 3R, 4, 4X or 12 enclosures



RAL 7035 Light Gray P/N*	ANSI 61 Dark Gray P/N*	Trade Size Ref. (nom. In.)	Plugged Hole Dia. Range (In.)	Wall Thickness Range (In.)	A Plug Diameter (In.)	B Plug Head Height (In.)	C Nut Diameter (In.)	D Nut Height (In.)	E Across Flats (In.)
AMHSPL-S	AMHSPL-SGY	Pilot Light (.500)	.500-.624	.059-.250	1.120	0.235	1.060	0.500	0.545
AMHSPL	AMHSPL-GY	Pilot Light (.625)	.625-.812	.059-.250	1.120	0.235	1.060	0.500	0.545
AMHS050	AMHS050-GY	1/2" Conduit (.875) 22mm PB (.886)	.812-.937	.059-.250	1.245	0.235	1.185	0.500	0.605
AMHS075	AMHS075-GY	3/4" Conduit (1.109) 30mm PB (1.210)	1.000-1.312	.059-.250	1.620	0.235	1.560	0.500	0.945
AMHS100	AMHS100-GY	1" Conduit (1.375)	1.375-1.625	.059-.250	1.923	0.235	1.873	0.500	0.945
AMHS125	AMHS125-GY	1-1/4" Conduit (1.734)	1.687-1.875	.059-.250	2.183	0.235	2.123	0.500	1.195
AMHS150	AMHS150-GY	1-1/2" Conduit (1.984)	2.000-2.187	.059-.250	2.495	0.235	2.435	0.500	1.195
AMHS200	AMHS200-GY	2" Conduit (2.469)	2.500-2.75	.059-.250	3.120	0.235	3.060	0.750	1.291
AMHS250	AMHS250-GY	2-1/2" Conduit (2.969)	2.875-3.125	.059-.250	3.495	0.235	3.435	0.750	1.491
AMHS300	AMHS300-GY	3" Conduit (3.594)	3.500-3.750	.059-.250	4.120	0.235	4.060	0.750	1.491
AMHS350	AMHS350-GY	3-1/2" Conduit (4.125)	4.000-4.250	.059-.250	4.620	0.235	4.560	0.750	1.491
AMHS400	AMHS400-GY	4" Conduit (4.641)	4.500-4.750	.059-.250	5.120	0.235	5.060	0.750	1.491

\*Note: Made of general purpose polycarbonate (PC). PC can be used as a substitute for carbon steel plug applications plus many stainless steel and other nonmetallic plug applications. Please check industry standard corrosion guides for additional application assistance.



**ALLIED  
MOULDED  
PRODUCTS, Inc.**



[www.alliedmoulded.com](http://www.alliedmoulded.com)