Table of contents

004–024	S(U)200 series miniature circuit breakers UL 489 series
025–048	S200 series miniature circuit breakers UL 1077 series
049–056	Application guide
057–073	S800U series miniature circuit breakers UL 489 series
074–085	S800C series miniature circuit breakers UL 1077 series
086–087	EPD24 electronic protection device

S(U)200 series — SU200M, SU200MR, and S200UDC

UL 489 series



Description

The SU200M, SU200MR and S200UDC miniature circuit breakers offer a compact solution for protection requirements. The SU200 series devices are current-limiting according to UL 489 and DIN rail mounted.

SU200M, SU200MR and S200UDC MCBs come in up to three trip curves to provide maximum circuit protection.

For the worldwide market, the breakers carry UL, CSA, IEC, CE and many other agency approvals and certifications.





Features

- UL current limiting
- Fast breaking time (2.3–2.5 ms)
- Bus connection system
- Wide range of accessories
- Available with variable depth handle mechanism
- CE certified and marked
- DIN rail mounting
- Finger-safe terminals
- Multi-function terminals
- Suitable for reverse feed (except for S200UDC)
- UL 489 listed branch circuit protective device, UL File #E212323

	SU200M	SU200MR	S200UDC
Amperage	0.2–63 A	0.2–63 A	1–63 A
Voltage	up to 277/Y480 V AC 48/96 V DC	up to 277/480 V AC	60/125 V DC
Trip curves	Z, C, K	K	Z, K
Interrupt rating	10 kA	10 kA	14 kA
Auxiliary contacts	Yes	Yes	Yes
Bell alarm	Yes	Yes	Yes
Shunt trip	Yes	Yes	Yes
Busbar	Yes	Yes	Yes

SU200M-C

Branch circuit protection — UL 489, CSA 22.2 No. 5



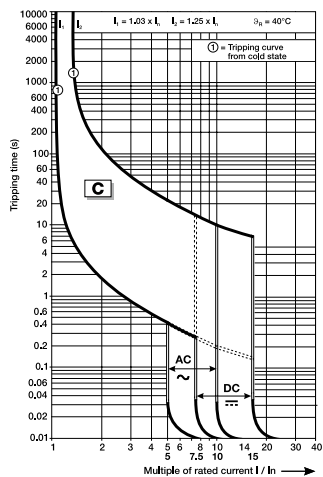

Number of poles	Rated current		Cat. no.	Number of poles	Rated current	
	I_n A				I_n A	Cat. no.
   	1	0.5	SU201M-C0.5	3	0.5	SU203M-C0.5
		1	SU201M-C1		1	SU203M-C1
		1.6	SU201M-C1.6		1.6	SU203M-C1.6
		2	SU201M-C2		2	SU203M-C2
		3	SU201M-C3		3	SU203M-C3
		4	SU201M-C4		4	SU203M-C4
		5	SU201M-C5		5	SU203M-C5
		6	SU201M-C6		6	SU203M-C6
		7	SU201M-C7		7	SU203M-C7
		8	SU201M-C8		8	SU203M-C8
		10	SU201M-C10		10	SU203M-C10
		13	SU201M-C13		13	SU203M-C13
		15	SU201M-C15		15	SU203M-C15
		16	SU201M-C16		16	SU203M-C16
		20	SU201M-C20		20	SU203M-C20
		25	SU201M-C25		25	SU203M-C25
		30	SU201M-C30		30	SU203M-C30
		32	SU201M-C32		32	SU203M-C32
	35	SU201M-C35		35	SU203M-C35	
	40	SU201M-C40		40	SU203M-C40	
	50	SU201M-C50		50	SU203M-C50	
	60	SU201M-C60		60	SU203M-C60	
	63	SU201M-C63		63	SU203M-C63	
2	0.5	SU202M-C0.5	4	0.5	SU204M-C0.5	
	1	SU202M-C1		1	SU204M-C1	
	1.6	SU202M-C1.6		1.6	SU204M-C1.6	
	2	SU202M-C2		2	SU204M-C2	
	3	SU202M-C3		3	SU204M-C3	
	4	SU202M-C4		4	SU204M-C4	
	5	SU202M-C5		5	SU204M-C5	
	6	SU202M-C6		6	SU204M-C6	
	7	SU202M-C7		7	SU204M-C7	
	8	SU202M-C8		8	SU204M-C8	
	10	SU202M-C10		10	SU204M-C10	
	13	SU202M-C13		13	SU204M-C13	
	15	SU202M-C15		15	SU204M-C15	
	16	SU202M-C16		16	SU204M-C16	
	20	SU202M-C20		20	SU204M-C20	
	25	SU202M-C25		25	SU204M-C25	
	30	SU202M-C30		30	SU204M-C30	
		32	SU202M-C32		32	SU204M-C32
	35	SU202M-C35		35	SU204M-C35	
	40	SU202M-C40		40	SU204M-C40	
	50	SU202M-C50		50	SU204M-C50	
	60	SU202M-C60		60	SU204M-C60	
	63	SU202M-C63		63	SU204M-C63	

Diagram



SU200M-K

Branch circuit protection — UL 489, CSA 22.2 No. 5



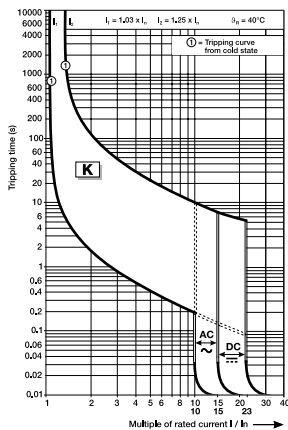

	Number of poles	Rated current		Number of poles	Rated current				
		I_n A	Cat. no.		I_n A	Cat. no.			
	1	0.2	SU201M-K0.2	3	0.2	SU203M-K0.2			
		0.3	SU201M-K0.3		0.3	SU203M-K0.3			
		0.5	SU201M-K0.5		0.5	SU203M-K0.5			
		0.75	SU201M-K0.75		0.75	SU203M-K0.75			
		1	SU201M-K1		1	SU203M-K1			
		1.6	SU201M-K1.6		1.6	SU203M-K1.6			
		2	SU201M-K2		2	SU203M-K2			
		3	SU201M-K3		3	SU203M-K3			
		4	SU201M-K4		4	SU203M-K4			
		5	SU201M-K5		5	SU203M-K5			
		6	SU201M-K6		6	SU203M-K6			
		7	SU201M-K7		7	SU203M-K7			
		8	SU201M-K8		8	SU203M-K8			
		10	SU201M-K10		10	SU203M-K10			
		13	SU201M-K13		13	SU203M-K13			
		15	SU201M-K15		15	SU203M-K15			
			2		0.2	SU202M-K0.2	4	0.2	SU204M-K0.2
					0.3	SU202M-K0.3		0.3	SU204M-K0.3
0.5	SU202M-K0.5			0.5	SU204M-K0.5				
0.75	SU202M-K0.75			0.75	SU204M-K0.75				
1	SU202M-K1			1	SU204M-K1				
1.6	SU202M-K1.6			1.6	SU204M-K1.6				
2	SU202M-K2			2	SU204M-K2				
3	SU202M-K3			3	SU204M-K3				
4	SU202M-K4			4	SU204M-K4				
5	SU202M-K5			5	SU204M-K5				
6	SU202M-K6			6	SU204M-K6				
7	SU202M-K7			7	SU204M-K7				
8	SU202M-K8			8	SU204M-K8				
10	SU202M-K10			10	SU204M-K10				
13	SU202M-K13			13	SU204M-K13				
15	SU202M-K15			15	SU204M-K15				
	3			0.2	SU203M-K0.2	3		0.2	SU203M-K0.2
				0.3	SU203M-K0.3			0.3	SU203M-K0.3
		0.5	SU203M-K0.5	0.5	SU203M-K0.5				
		0.75	SU203M-K0.75	0.75	SU203M-K0.75				
		1	SU203M-K1	1	SU203M-K1				
		1.6	SU203M-K1.6	1.6	SU203M-K1.6				
		2	SU203M-K2	2	SU203M-K2				
		3	SU203M-K3	3	SU203M-K3				
		4	SU203M-K4	4	SU203M-K4				
		5	SU203M-K5	5	SU203M-K5				
		6	SU203M-K6	6	SU203M-K6				
		7	SU203M-K7	7	SU203M-K7				
		8	SU203M-K8	8	SU203M-K8				
		10	SU203M-K10	10	SU203M-K10				
		13	SU203M-K13	13	SU203M-K13				
		15	SU203M-K15	15	SU203M-K15				
			4	0.2	SU204M-K0.2		4	0.2	SU204M-K0.2
				0.3	SU204M-K0.3			0.3	SU204M-K0.3
0.5	SU204M-K0.5			0.5	SU204M-K0.5				
0.75	SU204M-K0.75			0.75	SU204M-K0.75				
1	SU204M-K1			1	SU204M-K1				
1.6	SU204M-K1.6			1.6	SU204M-K1.6				
2	SU204M-K2			2	SU204M-K2				
3	SU204M-K3			3	SU204M-K3				
4	SU204M-K4			4	SU204M-K4				
5	SU204M-K5			5	SU204M-K5				
6	SU204M-K6			6	SU204M-K6				
7	SU204M-K7			7	SU204M-K7				
8	SU204M-K8			8	SU204M-K8				
10	SU204M-K10			10	SU204M-K10				
13	SU204M-K13			13	SU204M-K13				
15	SU204M-K15			15	SU204M-K15				

Diagram



SU200M-Z

Branch circuit protection — UL 489, CSA 22.2 No. 5



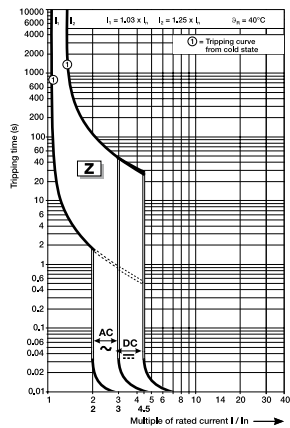

Number of poles	Rated current		Number of poles	Rated current	
	I_n A	Cat. no.		I_n A	Cat. no.
	0.5	SU201M-Z0.5		0.5	SU203M-Z0.5
	1	SU201M-Z1		1	SU203M-Z1
	1.6	SU201M-Z1.6		1.6	SU203M-Z1.6
	2	SU201M-Z2		2	SU203M-Z2
	3	SU201M-Z3		3	SU203M-Z3
	4	SU201M-Z4		4	SU203M-Z4
	5	SU201M-Z5		5	SU203M-Z5
	6	SU201M-Z6		6	SU203M-Z6
	7	SU201M-Z7		7	SU203M-Z7
	8	SU201M-Z8		8	SU203M-Z8
	10	SU201M-Z10		10	SU203M-Z10
	13	SU201M-Z13		13	SU203M-Z13
	15	SU201M-Z15		15	SU203M-Z15
	16	SU201M-Z16		16	SU203M-Z16
	20	SU201M-Z20		20	SU203M-Z20
25	SU201M-Z25	25	SU203M-Z25		
30	SU201M-Z30	30	SU203M-Z30		
32	SU201M-Z32	32	SU203M-Z32		
35	SU201M-Z35	35	SU203M-Z35		
40	SU201M-Z40	40	SU203M-Z40		
50	SU201M-Z50	50	SU203M-Z50		
60	SU201M-Z60	60	SU203M-Z60		
63	SU201M-Z63	63	SU203M-Z63		
	0.5	SU202M-Z0.5		0.5	SU204M-Z0.5
	1	SU202M-Z1		1	SU204M-Z1
	1.6	SU202M-Z1.6		1.6	SU204M-Z1.6
	2	SU202M-Z2		2	SU204M-Z2
	3	SU202M-Z3		3	SU204M-Z3
	4	SU202M-Z4		4	SU204M-Z4
	5	SU202M-Z5		5	SU204M-Z5
	6	SU202M-Z6		6	SU204M-Z6
	7	SU202M-Z7		7	SU204M-Z7
	8	SU202M-Z8		8	SU204M-Z8
	10	SU202M-Z10		10	SU204M-Z10
	13	SU202M-Z13		13	SU204M-Z13
	15	SU202M-Z15		15	SU204M-Z15
	16	SU202M-Z16		16	SU204M-Z16
	20	SU202M-Z20		20	SU204M-Z20
25	SU202M-Z25	25	SU204M-Z25		
30	SU202M-Z30	30	SU204M-Z30		
32	SU202M-Z32	32	SU204M-Z32		
35	SU202M-Z35	35	SU204M-Z35		
40	SU202M-Z40	40	SU204M-Z40		
50	SU202M-Z50	50	SU204M-Z50		
60	SU202M-Z60	60	SU204M-Z60		
63	SU202M-Z63	63	SU204M-Z63		

Diagram



SU200MR-K with ring tongue terminals

Branch circuit protection — UL 489, CSA 22.2 No. 5

				Rated current				Rated current		
				I_n				I_n		
				A	Cat. no.	Number of poles			A	Cat. no.
	1			0.2	SU201MR-K0.2	3			0.2	SU203MR-K0.2
				0.3	SU201MR-K0.3				0.3	SU203MR-K0.3
				0.5	SU201MR-K0.5				0.5	SU203MR-K0.5
				0.75	SU201MR-K0.75				0.75	SU203MR-K0.75
				1	SU201MR-K1				1	SU203MR-K1
				1.6	SU201MR-K1.6				1.6	SU203MR-K1.6
				2	SU201MR-K2				2	SU203MR-K2
				3	SU201MR-K3				3	SU203MR-K3
				4	SU201MR-K4				4	SU203MR-K4
				5	SU201MR-K5				5	SU203MR-K5
				6	SU201MR-K6				6	SU203MR-K6
				8	SU201MR-K8				8	SU203MR-K8
				10	SU201MR-K10				10	SU203MR-K10
				13	SU201MR-K13				13	SU203MR-K13
				15	SU201MR-K15				15	SU203MR-K15
				16	SU201MR-K16				16	SU203MR-K16
				20	SU201MR-K20				20	SU203MR-K20
					2					
0.3	SU202MR-K0.3	0.3	SU204MR-K0.3							
0.5	SU202MR-K0.5	0.5	SU204MR-K0.5							
0.75	SU202MR-K0.75	0.75	SU204MR-K0.75							
1	SU202MR-K1	1	SU204MR-K1							
1.6	SU202MR-K1.6	1.6	SU204MR-K1.6							
2	SU202MR-K2	2	SU204MR-K2							
3	SU202MR-K3	3	SU204MR-K3							
4	SU202MR-K4	4	SU204MR-K4							
5	SU202MR-K5	5	SU204MR-K5							
6	SU202MR-K6	6	SU204MR-K6							
8	SU202MR-K8	8	SU204MR-K8							
10	SU202MR-K10	10	SU204MR-K10							
13	SU202MR-K13	13	SU204MR-K13							
15	SU202MR-K15	15	SU204MR-K15							
16	SU202MR-K16	16	SU204MR-K16							
20	SU202MR-K20	20	SU204MR-K20							
	3					0.2	SU201MR-K0.2	3		
				0.3	SU201MR-K0.3	0.3	SU203MR-K0.3			
				0.5	SU201MR-K0.5	0.5	SU203MR-K0.5			
				0.75	SU201MR-K0.75	0.75	SU203MR-K0.75			
				1	SU201MR-K1	1	SU203MR-K1			
				1.6	SU201MR-K1.6	1.6	SU203MR-K1.6			
				2	SU201MR-K2	2	SU203MR-K2			
				3	SU201MR-K3	3	SU203MR-K3			
				4	SU201MR-K4	4	SU203MR-K4			
				5	SU201MR-K5	5	SU203MR-K5			
				6	SU201MR-K6	6	SU203MR-K6			
				8	SU201MR-K8	8	SU203MR-K8			
				10	SU201MR-K10	10	SU203MR-K10			
				13	SU201MR-K13	13	SU203MR-K13			
				15	SU201MR-K15	15	SU203MR-K15			
				16	SU201MR-K16	16	SU203MR-K16			
				20	SU201MR-K20	20	SU203MR-K20			
					4				0.2	SU202MR-K0.2
0.3	SU202MR-K0.3	0.3	SU204MR-K0.3							
0.5	SU202MR-K0.5	0.5	SU204MR-K0.5							
0.75	SU202MR-K0.75	0.75	SU204MR-K0.75							
1	SU202MR-K1	1	SU204MR-K1							
1.6	SU202MR-K1.6	1.6	SU204MR-K1.6							
2	SU202MR-K2	2	SU204MR-K2							
3	SU202MR-K3	3	SU204MR-K3							
4	SU202MR-K4	4	SU204MR-K4							
5	SU202MR-K5	5	SU204MR-K5							
6	SU202MR-K6	6	SU204MR-K6							
8	SU202MR-K8	8	SU204MR-K8							
10	SU202MR-K10	10	SU204MR-K10							
13	SU202MR-K13	13	SU204MR-K13							
15	SU202MR-K15	15	SU204MR-K15							
16	SU202MR-K16	16	SU204MR-K16							
20	SU202MR-K20	20	SU204MR-K20							

Diagram

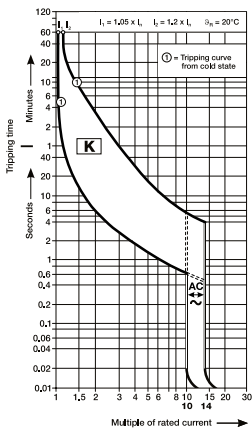

S200UDC-K

Branch circuit protection — UL 489, CSA 22.2 No. 5

	Number of poles	Rated current		Cat. no.
		I_n A		
	1	1		S201UDC-K1
		1.6		S201UDC-K1.6
		2		S201UDC-K2
		3		S201UDC-K3
		4		S201UDC-K4
		5		S201UDC-K5
		6		S201UDC-K6
		8		S201UDC-K8
		10		S201UDC-K10
		13		S201UDC-K13
		15		S201UDC-K15
		16		S201UDC-K16
		20		S201UDC-K20
		25		S201UDC-K25
		30		S201UDC-K30
		32		S201UDC-K32
40		S201UDC-K40		
50		S201UDC-K50		
60		S201UDC-K60		
63		S201UDC-K63		
	2	1		S202UDC-K1
		1.6		S202UDC-K1.6
		2		S202UDC-K2
		3		S202UDC-K3
		4		S202UDC-K4
		5		S202UDC-K5
		6		S202UDC-K6
		8		S202UDC-K8
		10		S202UDC-K10
		13		S202UDC-K13
		15		S202UDC-K15
		16		S202UDC-K16
		20		S202UDC-K20
		25		S202UDC-K25
		30		S202UDC-K30
		32		S202UDC-K32
40		S202UDC-K40		
50		S202UDC-K50		
60		S202UDC-K60		
63		S202UDC-K63		

Diagram

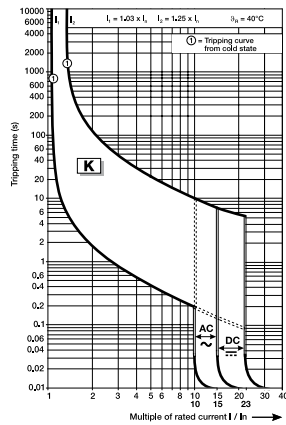

S200UDC-Z

Branch circuit protection — UL 489, CSA 22.2 No. 5

	Number of poles	Rated current		Cat. no.
		I_n	A	
	1	1	S201UDC-Z1	
		1.6	S201UDC-Z1.6	
		2	S201UDC-Z2	
		3	S201UDC-Z3	
		4	S201UDC-Z4	
		5	S201UDC-Z5	
		6	S201UDC-Z6	
		8	S201UDC-Z8	
		10	S201UDC-Z10	
		13	S201UDC-Z13	
		15	S201UDC-Z15	
		16	S201UDC-Z16	
		20	S201UDC-Z20	
		25	S201UDC-Z25	
		30	S201UDC-Z30	
		32	S201UDC-Z32	
		40	S201UDC-Z40	
		50	S201UDC-Z50	
		60	S201UDC-Z60	
		63	S201UDC-Z63	
	2	1	S202UDC-Z1	
		1.6	S202UDC-Z1.6	
		2	S202UDC-Z2	
		3	S202UDC-Z3	
		4	S202UDC-Z4	
		5	S202UDC-Z5	
		6	S202UDC-Z6	
		8	S202UDC-Z8	
		10	S202UDC-Z10	
		13	S202UDC-Z13	
		15	S202UDC-Z15	
		16	S202UDC-Z16	
		20	S202UDC-Z20	
		25	S202UDC-Z25	
30	S202UDC-Z30			
32	S202UDC-Z32			
40	S202UDC-Z40			
50	S202UDC-Z50			
60	S202UDC-Z60			
63	S202UDC-Z63			

Diagram

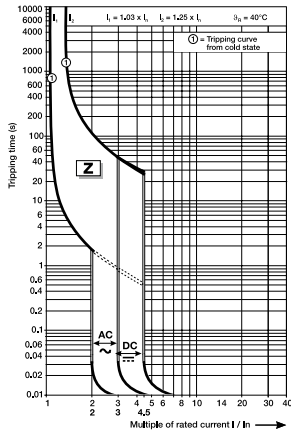

Note: Standard UL 489 (only DC; please note polarity of device).

Accessories

SU200M, SU200MR and S200UDC — UL 489, CSA 22.2 No. 5

Auxiliary contacts

The auxiliary contacts will signal whether the breaker is in the on or off position.

	Description	Cat. no.
	For field mounting: right side	S2C-H6RU

Shunt trip

For remote tripping of breaker, a shunt trip device can be added to the MCB. The solenoid device opens the breaker after control voltage is applied.

	Description	Cat. no.
	For field mounting: right side 12...60 V AC/DC	S2C-A1U
	For field mounting: right side 110...415 V AC 110...250 V DC	S2C-A2U

Note: For shafts and handles, refer to parts in the Disconnect Switch and MCCB section.

Bell alarm

The bell alarm includes a set of contacts that will only signal when the breaker has tripped. Typically, the contacts would be connected to an alarm or bell to signal the operator that an over-current trip has occurred. The bell alarm also includes a test button for testing the alarm contacts without opening the breaker.

	Description	Cat. no.
	For field mounting: right side	S2C-S6RU

Possible mounting arrangements of MCB accessories

Legend

Auxiliary contact	H
Bell alarm/auxiliary contact	S/H
Bell alarm/auxiliary contact used as auxiliary contact	S/H (H)
Shunt trip	ST

Note: Right-hand mount accessories cannot be used in conjunction with S2C-DH, rotary operating mechanism.

Diagram

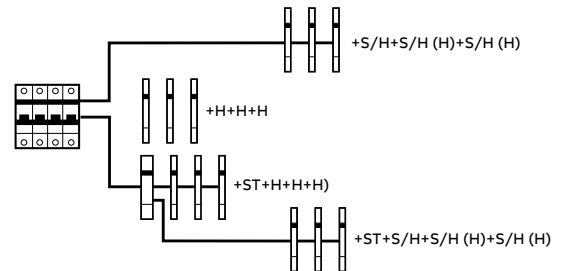

Accessories

SU200M, SU200MR and S200UDC — UL 489, CSA 22.2 No. 5

Rotary operating mechanism

For the actuation of 2-, 3- or 4-pole miniature circuit breakers in closed distribution boards for drive axles of 5 or 6 mm² (square).



Cat. no.

S2C-DH

Handles for use with rotary operating mechanism

Handle IP65, 65 x 65 mm, padlockable with max. 3 padlocks (bail diameter 5–8 mm), door interlock in ON-position, adjustable or non-adjustable.



Color	Cat. no.
Adjustable	
Black	OHBS2AJ
Yellow-red	OHYS2AJ
Silver	OHSS2AJ
Grey	OHGS2AJ
Non-adjustable	
Black	OHBS2AJ1
Yellow-red	OHYS2AJ1
Silver	OHSS2AJ1
Grey	OHGS2AJ1

* OH_2_J enables selection of MCB behavior when opening panel door (remain switched on or switch off). OH_2_J1 will cause MCB to switch off when opening panel door.

Shafts

Type and order numbers are for one piece.

For selector type handles. Shaft diameter 6 mm.

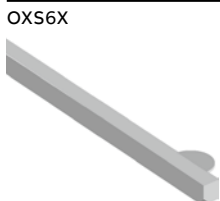

Length (mm)	Cat. no.
85	OXS6X85
105	OXS6X105
120	OXS6X120
130	OXS6X130
160	OXS6X160
180	OXS6X180
250	OXS6X250
330	OXS6X330

Accessories

SU200M, SU200MR and S200UDC — UL 489, CSA 22.2 No. 5

Connection drawings

Bell alarm S2C-S6RU

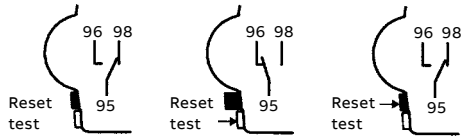

In ON and OFF position after hand operation

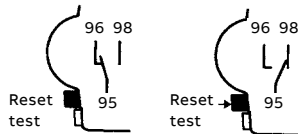

In OFF position after tripping

Auxiliary contact S2C-H6RU

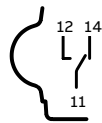

Auxiliary contact in ON position

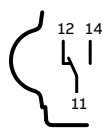

Auxiliary contact in OFF position

Shunt trip S2C-A...U



Mounting

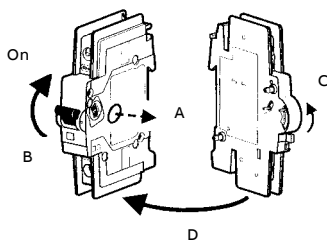

Addition of a S2C-H6RU auxiliary contact

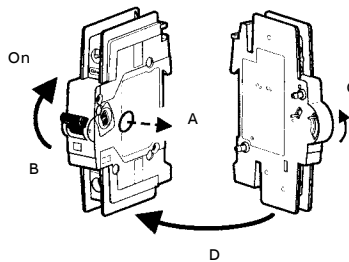

Addition of a S2C-S6RU bell alarm contact

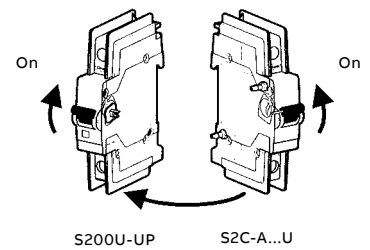

Addition of a S2C-A...U shunt trip

Accessories

SU200MR — UL 489, CSA 22.2 No. 5

SU200MR Instructions for use

Ring Tongue Terminal, Special purpose - Not for general use

Installation Instructions

Please insert or withdraw the cable lug only when the screw is completely open.

Please make sure that the terminal screw penetrates the ring lug hole properly and completely during tightening.

Please ensure that the screw is securely tightened before applying any mechanical force on the cable / cable lug.

Do not apply abnormal downward pressure on the screw during tightening or loosening of the screw.

F = max. 30 N F = Maximum to operate

Please follow the Ring Tongue Details on the rear of this sheet.

Ring Tongue Details

Only or ring cable lugs	Insulated only 	A max. 11.0 mm (0.43")	B max. 12.2 mm (0.48")	C Suitable for M5 (0.20")
	Insulated only 	A max. 14.0 mm (0.55")	B max. 12.2 mm (0.48")	C Suitable for M5 (0.20")

CU only
 60/75°C
 (140/167°F)
 PZ 2 Torque: 2.8 Nm (25lb-in)

Accessories

SU200M, SU200MR and S200UDC — UL 489, CSA 22.2 No. 5

Busbars for SU200M

Busbars cannot be cut. 600 V AC/DC.



	Amp rating*	Number of poles	Phases	Busbar length (mm)	Cat. no.
	80/115	6	1	103.2	PS 1/6/16BP
		12	1	208.8	PS 1/12/16BP
		18	1	314.4	PS 1/18/16BP
	80/115	6	2	103.2	PS 2/6/16BP
		12	2	208.8	PS 2/12/16BP
		18	2	314.4	PS 2/18/16BP
	80/115	6	3	103.2	PS 3/6/16BP
		12	3	208.8	PS 3/12/16BP
		18	3	314.4	PS 3/18/16BP

*Depending on enclosure size

Busbar tooth covers for BS...BP (UL 489)

	Description	Cat. no.
	Covers three unused poles of busbar	BSK-BP

Feeder terminals for PS...BP (UL 489)

	Description	Cat. no.
	Terminal, insulated with pin contact	AST35/15BP
	Feeder terminal, single-pole terminal, can be mounted side by side, feed on the pin of the busbar	SZ-ESK BP

Busbars PS...BP-C for use with end caps PS-END 3 BP-C

	Number of phases	Phase sequence	Cat. no.
	1	L1-L1-L1...	PS1/57/25BP-C
		L1-Aux (free)-L1-Aux (free)...1	PS1/37/25HBP-C
	2	L1-L2-L1-L2...	PS2/56/25BP-C
		L1-L2-Aux (free)-L1-L2-Aux (free)...1	PS2/46/25HBP-C
	3	L1-L2-L3-L1-L2-L3...	PS3/57/25BP-C
		L1-L2-L3-Aux (free)-L1-L2-L3-Aux (free)...1	PS3/48/25HBP-C
		L1-Aux (free)-L2-Aux (free)-L3-Aux (free)...1	PS3/39/25HBP-C

¹⁾ For devices with auxiliary contact (half module) after each phase sequence

Accessories

Description	Cat. no.
Tooth covers, for 3 pins	BSK BP-C
End caps	PS-END 3 BP-C
Feeder terminal	AST 35/58 BP-C

Accessories

SU200M, SU200MR and S200UDC — UL 489, CSA 22.2 No. 5

Busbars for SU200MR, can be cut to length

Busbars PS...BP-CR for use with end caps PS-END 3 BP-C

	Number of phases	Phase sequence	Number of pins pc.	Cross section mm ²	Cat. no.
	1	L1-L1-L1...	57	25	PS1/57/25BP-CR
		L1-Aux (free)-L1-Aux (free)...1)	37	25	PS1/37/25HBP-CR
	2	L1-L2-L1-L2...	56	25	PS2/56/25BP-CR
		L1-L2-Aux (free)-L1-L2-Aux (free)...1)	46	25	PS2/46/25HBP-CR
	3	L1-L2-L3-L1-L2-L3...	57	25	PS3/57/25BP-CR
		L1-L2-L3-Aux (free)-L1-L2-L3-Aux (free)...1)	48	25	PS3/48/25HBP-CR
	L1-Aux (free)-L2-Aux (free)-L3-Aux (free)...1)	39	25	PS3/39/25HBP-CR	

¹⁾ For devices with auxiliary contact (half module) after each phase sequence

Accessories

Description	Cat. no.
Tooth covers, for 3 pins	BSK BP-CR
End caps	PS-END 3 BP-C

Lockout/tag out device

Product description	Cat. no.
For single-pole MCBs	S2C-LOTO-S
For multi-pole MCBs	S2C-LOTO-M



Filling piece

For heat dissipation of closely mounted devices that generate much heat. Width 8.75 mm, as spacer, two different heights, breakable, for DIN rails according to DIN EN 60 715, 35 x 7.5 mm.

Product description	Weight 1 piece kg	Pack unit pc.	Cat. no.
Filling piece	0.01	25	SZ-FST 2





Accessories

SU200M, SU200MR and S200UDC — UL 489, CSA 22.2 No. 5

False poles

		Weight 1 piece kg	Pack unit pc.	Cat. no.
	False pole — 1 module	0.01	100	FP1
	Support for false pole	0.012	10	SFP

Front-mount brackets

	Product description	Cat. no.
	Up to 10 MCB poles	S500-ME
	For one MCB pole	MB-CL1
	For two MCB poles	MB-CL2
	For three MCB poles	MB-CL3
		
	Up to three MCB poles	MB-3PD

Technical specifications

SU200M, SU200MR and S200UDC — UL 489, CSA 22.2 No. 5

Technical specifications

	SU200M	SU200MR	S200UDC
Specifications	UL 489, C 22.2 No. 5, IEC 60947-2	UL 489, C 22.2 No. 5, IEC 60947-2	UL 489, VDE 0660
UL file number	E 212323, UL current limiting	E 212323, UL current limiting	E212323
Number of poles	1, 2, 3, 4	1, 2, 3, 4	1, 2
Trip curves	C, K, Z	K	Z, K
Rated current	Up to 63 A	Up to 63 A	Up to 63 A
Rated voltage	277/Y480 V AC up to 40 A (Z and C trip curves) 277/Y480 V AC up to 35 A (K trip curve) 240 V AC up to 63 A (all trip curves) 48/96 V DC up to 63 A (1/2-pole, all trip curves)	277/Y480 V AC (up to 35 A) 240 V AC up to 63 A	60/125 V DC (1/2-pole)
Short circuit interrupt rating	10 kA	10 kA	14 kA
Calibration temperature	40 °C	40 °C	25 °C
Mounting position	Any	Any	Any
Protection degree	IP 20	IP 20	IP 20 with accessory
Mounting	35 mm DIN rail	35 mm DIN rail	35 mm DIN rail
Terminal screw tightening torque	25 in. lbs (2.8 Nm)	25 in. lbs (2.8 Nm)	25 in. lbs (2.8 Nm)
Cable size	4–16 AWG	4–16 AWG	4–16 AWG
Ambient temperature	-25 °C to 55 °C (-13 °F to 131 °F)	-25 °C to 55 °C (-13 °F to 131 °F)	-25 °C to 55 °C (-13 °F to 131 °F)
Shock resistance (IEC60068-2-27)	25 g - 2 shocks - 13 ms	25 g - 2 shocks - 13 ms	25 g - 2 shocks - 13 ms
Service life, mechanical	20,000 operations	20,000 operations	20,000 operations

Auxiliary contact S2C-H6RU and S2C-S6RU

Rated current	10
Rated voltage AC/DC	24
Contact	1 pole double throw
Connection capacity	18–14 AWG (0.75–2.5 mm ²)
Tightening torque	11 in. lbs (1.2 Nm)
Shock resistance acc. to DIN IEC 68-2-6	5 g, 20 frequency cycles 5...150...5 Hz at 24 V AC/DC, 5 mA auto-reclosing < 10 ms
Mechanical service life	10,000 operations

Shunt trip

		S2C-A1U	S2C-A2U
Rated voltage	V AC	12–60	110–415
	V DC	12–60	110–250
Maximum release duration	ms	<10	<10
Minimum release voltage	V AC	7	55
	V DC	10	80
Consumption on release	VA AC	40–200	55–210
	VA DC	40–200	55–110
Coil resistance	V	3.7	225
Terminals	AWG/mm ²	18–6/0.75–16	18–6/0.75–16
Tightening torque	in. lbs./Nm	18/2	18/2

Technical specifications

SU200M, SU200MR and S200UDC — UL 489, CSA 22.2 No. 5

Internal resistance and power loss per pole

Internal resistance per pole in mV, power loss per pole in W.

SU200M

Rated current I_n A	C, K characteristics		Z characteristics	
	Internal resistance per pole R_i mΩ	Power loss P_v W	Internal resistance per pole R_i mΩ	Power loss P_v W
0.2	42500	1.7	-	-
0.3	18889	1.7	-	-
0.5	5600	1.4	9000	2.3
0.75	2489	1.4	-	-
1	1400	1.4	2200	2.2
1.6	703	1.8	1000	2.6
2	450	1.8	650	2.6
3	178	1.6	250	2.3
4	113	1.8	140	2.2
5	50	1.3	100	2.5
6	56	2.0	70	2.5
8	23	1.5	28	1.8
10	21	2.1	21	2.1
13	14	2.3	17	2.9
15	11	2.4	13	2.9
16	9.8	2.5	10	2.6
20	6.3	2.5	6.5	2.6
25	5.1	3.2	5.1	3.2
30	3.9	3.5	3.9	3.5
32	3.6	3.7	3.6	3.7
35	3.3	4.1	3.3	4.1
40	2.8	4.5	2.8	4.5
50	1.8	4.5	1.8	4.5
60	1.4	4.9	1.4	4.9
63	1.4	5.4	1.4	5.4

SU200MR

Rated current A	Internal resistance per pole mΩ	Power loss per pole W
0.2	25300	1.01
0.3	13700	1.23
0.5	4740	1.19
0.75	2067	1.16
1	1270	1.27
1.5	610	1.56
2	442	1.77
3	140	1.26
4	109	1.75
5	50	1.26
6	54	1.94
8	22	1.41
10	18.2	1.82
13	14.8	2.50
15	8.1	1.83
16	11.1	2.83
20	8.5	3.40
25	5.5	3.43
30	3.8	3.39
32	4.6	4.70
35	3.9	4.76
40	2.8	4.40
50	1.7	4.25
60	1.7	6.18
63	1.9	7.56

Technical specifications

SU200M, SU200MR and S200UDC — UL 489, CSA 22.2 No. 5

Temperature derating for SU200M and SU200MR

Standard	Rated current I_n A	Maximum operating current at ambient temperature T A											
		- 40 °C	- 30 °C	- 20 °C	- 10 °C	0 °C	10 °C	20 °C	30 °C	40 °C	50 °C	60 °C	70 °C
UL 489	0.2 ¹⁾	0.27	0.26	0.25	0.24	0.23	0.22	0.22	0.21	0.20	0.19	0.19	0.18
	0.3 ¹⁾	0.40	0.39	0.37	0.36	0.35	0.33	0.32	0.31	0.30	0.29	0.28	0.27
	0.5	0.67	0.64	0.62	0.60	0.58	0.56	0.54	0.52	0.5	0.48	0.46	0.45
	0.75 ¹⁾	1.00	0.97	0.93	0.90	0.87	0.84	0.81	0.78	0.75	0.72	0.70	0.67
	1	1.34	1.29	1.24	1.20	1.16	1.12	1.08	1.04	1	0.96	0.93	0.89
	1.6	1.74	1.68	1.62	1.56	1.50	1.45	1.40	1.35	1.3	1.25	1.21	1.16
	2	2.67	2.58	2.49	2.40	2.31	2.23	2.15	2.07	2	1.93	1.85	1.79
	3	4.01	3.87	3.73	3.60	3.47	3.35	3.23	3.11	3	2.89	2.78	2.68
	4	5.35	5.16	4.97	4.80	4.63	4.46	4.30	4.15	4	3.85	3.71	3.57
	5	6.69	6.45	6.22	6.00	5.78	5.58	5.38	5.19	5	4.82	4.64	4.47
	6	8.02	7.74	7.46	7.20	6.94	6.69	6.45	6.22	6	5.78	5.56	5.36
	8	10.70	10.32	9.95	9.59	9.25	8.92	8.60	8.30	8	7.70	7.42	7.14
	10	13.37	12.90	12.44	11.99	11.56	11.15	10.75	10.37	10	9.63	9.27	8.93
	13	17.38	16.76	16.17	15.59	15.03	14.50	13.98	13.48	13	12.52	12.06	11.61
	15	20.06	19.34	18.65	17.99	17.35	16.73	16.13	15.56	15	14.45	13.91	13.40
	16	21.40	20.63	19.90	19.19	18.50	17.84	17.21	16.59	16	15.41	14.84	14.29
	20	26.75	25.79	24.87	23.98	23.13	22.30	21.51	20.74	20	19.26	18.55	17.86
	25	33.43	32.24	31.09	29.98	28.91	27.88	26.88	25.93	25	24.08	23.18	22.33
	30	40.12	38.69	37.31	35.98	34.69	33.45	32.26	31.11	30	28.89	27.82	26.79
32	42.79	41.27	39.79	38.37	37.01	35.69	34.41	33.18	32	30.82	29.68	28.58	
35	46.81	45.14	43.53	41.97	40.47	39.03	37.64	36.30	35	33.71	32.46	31.26	
40	53.49	51.58	49.74	47.97	46.26	44.61	43.01	41.48	40	38.52	37.09	35.72	
50	66.87	64.48	62.18	59.96	57.82	55.76	53.77	51.85	50	48.15	46.37	44.65	
60	80.24	77.38	74.61	71.95	69.39	66.91	64.52	62.22	60	57.78	55.64	53.58	
63	84.25	81.24	78.35	75.55	72.85	70.25	67.75	65.33	63	60.67	58.42	56.26	

¹⁾ Current ratings 0.2, 0.3 and 0.75 A available with K characteristic only.

Technical specifications

Busbars PS...BP-C/CR and accessories

Electrical data	Busbars PS...BP-C/CR
Standards	UL508 EN 60947-1 / IEC 60947-1:2004
Rated voltage U_e	600 V AC/DC
Rated frequency	50 Hz (IEC) / 60 Hz (UL)
Rated impulse withstand voltage U_{imp}	≥ 10 kV
Rated current / phase	
End fed ¹⁾	100 A
Center fed ¹⁾	200 A
Short circuit current rating	10 kA 3 cycles at 600 V / 140 kA fuse class J 200 A
Mechanical data	
Housing	Grey, RAL 7035
Resistance to climatic conditions	Acc. to DIN EN 60068
Isolation coordination	
Overvoltage category	III
Pollution degree	2
Installation	
Cross section	25 mm ²
Mounting position	Optional
Supply	Via cable with ring lug (PS...BP-CR); direct or via feeder terminal (PS...BP-C)
Accessories	
Shock protection caps	BSK BP-CR (for PS...BP-CR), BSK BP-C (for PS...BP-C)
Endcaps	PS-END 3 BP-C
Approvals	
	CE, RoHS
	UL 508: cULus listed

¹⁾ Independently from the current rating of the feeder terminal or busbar, the current-carrying capacity/current rating of the MCB terminal must not be exceeded.

Installation/assembly

Warning: When busbars are shortened, they must be deburred and cleaned of debris. Touch-safe only when used with the required end caps.

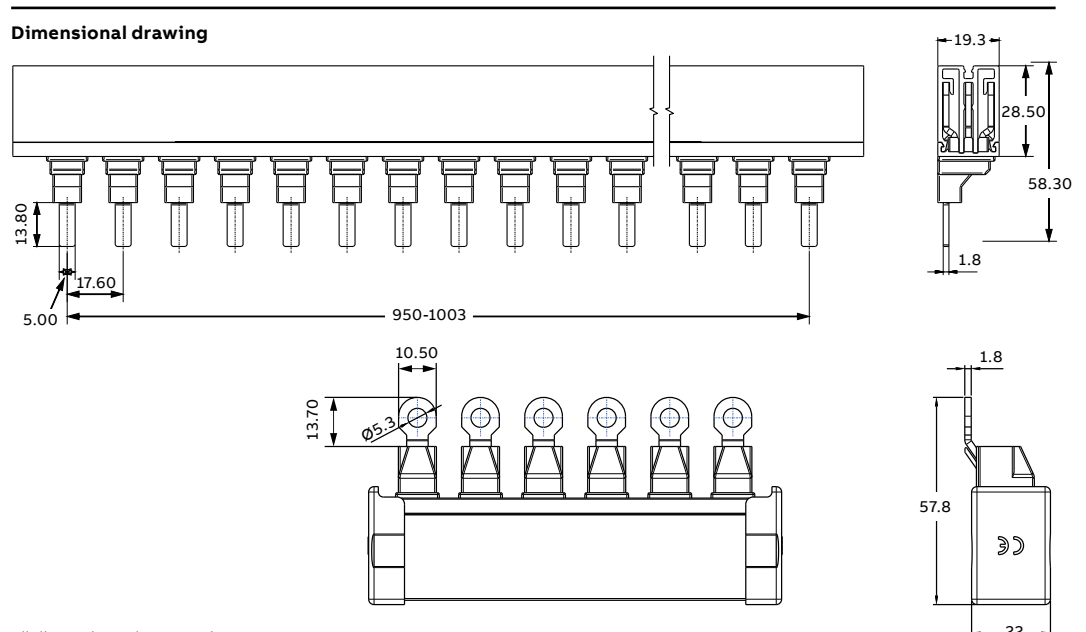

All dimensions shown are in mm.

Technical specifications

S200UDC series DC applications

DC = Direct current

S200UDC MCBs can be used in the one-pole version as 60 V DC, and in the 2-pole version with series connection of two poles up to 125 V DC.

S200UDC contains fitted permanent magnets, which assist in the forced extinguishing of the arc. If voltages to earth exceeding 60 V DC may occur, 2-pole S200UDC is to be used for one-pole disconnection.

For DC incoming supply from above S200UDC-... MCBs have, in the area of arc chutes, permanent magnets. It is therefore necessary to take into account the polarity during the installation process.

Doing so ensures that in the case of a short circuit, the magnetic field of the permanent magnets corresponds with the electromagnetic field of the short-circuit current, therefore safely leading the short circuit into the arc chute.

Incorrect polarities may cause damage to the MCB. This is why, in the case of top-fed devices, terminal 1 must be connected to (-) and terminal 3 to (+).

Example for permissible voltages between the conductors depending on the number of poles and circuit layout:

Voltage between conductors	Un	60 V	125 V	125 V	125 V
Voltage between conductor and earth	Un	60 V	60 V	125 V	60 V
MCB		1-pole S201UDC	2-pole S202UDC	2-pole S202UDC	2-pole S202UDC

Supply from below

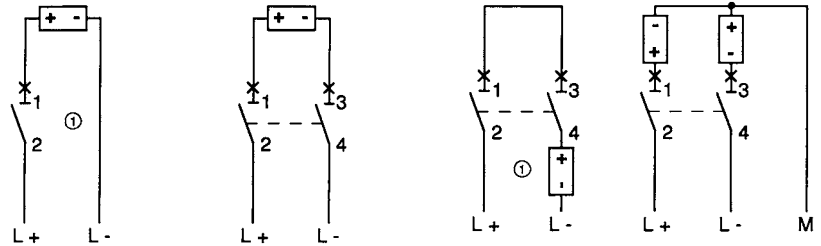

Supply from above

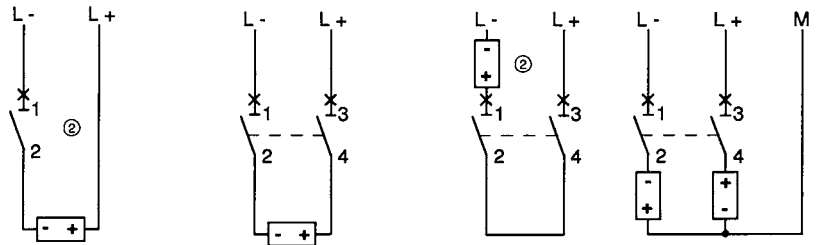

Technical specifications

S200UDC series DC applications

Examples for different voltage levels between conductor and earth in the case of identical voltage between conductors:

Voltage between conductors	U_n	125 V	125 V
		All-pole disconnection	1-pole disconnection
Voltage between conductor and earth	U_n	60 V	125 V
		Circuit symmetrically earthed	Circuit unsymmetrically earthed
MCB		2-pole	2-pole
		S202UDC	S202UDC

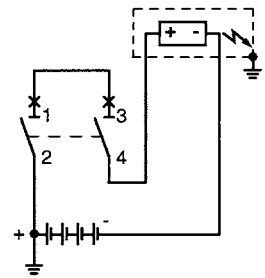
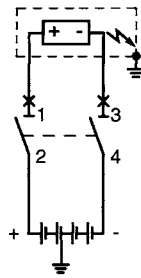

1 In the circuit diagram, the negative pole is earthed.

2 In the circuit diagram, the positive pole is earthed.

Approximate dimensions

SU200M, SU200MR and S200UDC — UL 489, CSA 22.2 No. 5

SU200M

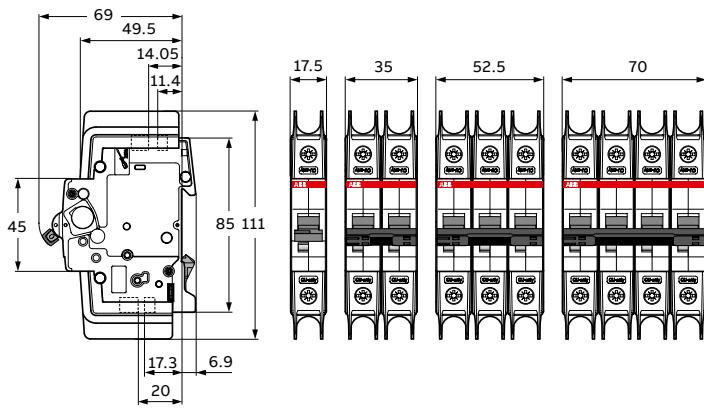

S200UDC

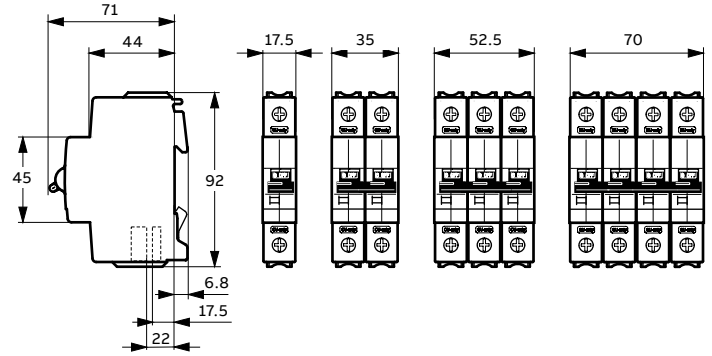

SU200MR

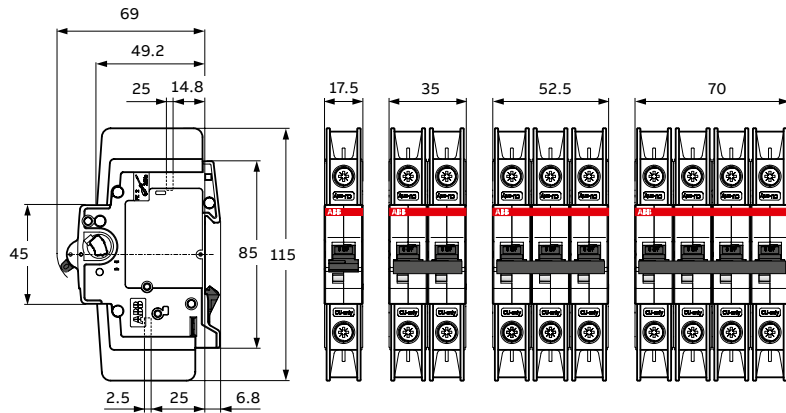

S2C-H6RU, S2C-S6RU

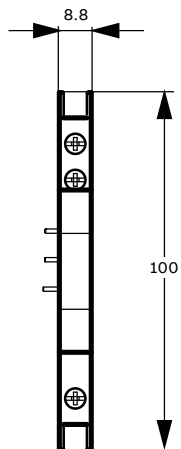

S2C-A..U

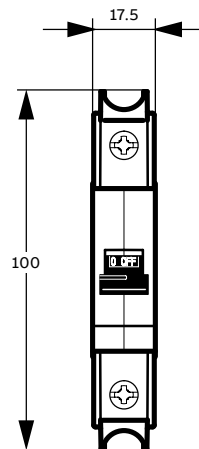

ST200M, S200MUC, S200MR series

UL 1077 series



Description

The UL 1077 family of supplementary protectors offers a compact solution for protection requirements. The devices are DIN rail mounted.

The UL 1077 MCBs are available with application-specific trip characteristics to provide maximum circuit protection.

The supplementary protectors offer thermal magnetic trip protection according to B, C, D, K and Z trip curves.

For the worldwide market, the breakers carry UL, CSA, IEC, CE and many other agency approvals and certifications.



Features

- Energy limiting
- Fast breaking time (2.3–2.5 ms)
- Bus connection system
- Wide range of accessories
- Available with variable depth handle mechanism
- CE certified and marked
- DIN rail mounting
- Finger-safe terminals
- Multi-function terminals
- Suitable for reverse feed
- UL 1077 recognized supplemental protective device, UL file #E76126

	ST200M	S200MR	S200MUC
Amperage	Up to 63 A	Up to 63 A	Up to 63 A
Voltage	277/Y480 V AC 60/125 V DC (1/2-pole)	277/Y480 V AC	277/Y480 V AC 250/500 V DC (1/2-pole)
Poles	1, 2, 3, 4	1, 2, 3, 4	1, 2, 3, 4
Trip curves	B, C, D, K, Z	K	C, K, Z
Short circuit interrupt rating	Up to 10 kA	10 kA	10 kA
Auxiliary contacts	Yes	Yes	Yes
Bell alarm	Yes	Yes	Yes
Shunt trip	Yes	Yes	Yes
Undervoltage release	Yes	Yes	Yes
Busbar	Yes	Yes	Yes

ST200M-B

Supplemental protectors — UL 1077, CSA 22.2 No. 235

	Number of poles	Rated current		Number of poles	Rated current	
		I_n A	Cat. no.		I_n A	Cat. no.
	1	0.5	ST201M-B0.5	2	0.5	ST202M-B0.5
		1	ST201M-B1		1	ST202M-B1
		1.6	ST201M-B1.6		1.6	ST202M-B1.6
		2	ST201M-B2		2	ST202M-B2
		3	ST201M-B3		3	ST202M-B3
		4	ST201M-B4		4	ST202M-B4
		5	ST201M-B5		5	ST202M-B5
		6	ST201M-B6		6	ST202M-B6
		7	ST201M-B7		7	ST202M-B7
		8	ST201M-B8		8	ST202M-B8
		10	ST201M-B10		10	ST202M-B10
		13	ST201M-B13		13	ST202M-B13
		15	ST201M-B15		15	ST202M-B15
		16	ST201M-B16		16	ST202M-B16
		20	ST201M-B20		20	ST202M-B20
		25	ST201M-B25		25	ST202M-B25
		30	ST201M-B30		30	ST202M-B30
		32	ST201M-B32		32	ST202M-B32
		35	ST201M-B35		35	ST202M-B35
40	ST201M-B40	40	ST202M-B40			
50	ST201M-B50	50	ST202M-B50			
60	ST201M-B60	60	ST202M-B60			
63	ST201M-B63	63	ST202M-B63			
	1+N	0.5	ST201M-B0.5NA	3	0.5	ST203M-B0.5
		1	ST201M-B1NA		1	ST203M-B1
		1.6	ST201M-B1.6NA		1.6	ST203M-B1.6
		2	ST201M-B2NA		2	ST203M-B2
		3	ST201M-B3NA		3	ST203M-B3
		4	ST201M-B4NA		4	ST203M-B4
		5	ST201M-B5NA		5	ST203M-B5
		6	ST201M-B6NA		6	ST203M-B6
		7	ST201M-B7NA		7	ST203M-B7
		8	ST201M-B8NA		8	ST203M-B8
		10	ST201M-B10NA		10	ST203M-B10
		13	ST201M-B13NA		13	ST203M-B13
		15	ST201M-B15NA		15	ST203M-B15
		16	ST201M-B16NA		16	ST203M-B16
		20	ST201M-B20NA		20	ST203M-B20
		25	ST201M-B25NA		25	ST203M-B25
		30	ST201M-B30NA		30	ST203M-B30
		32	ST201M-B32NA		32	ST203M-B32
		35	ST201M-B35NA		35	ST203M-B35
40	ST201M-B40NA	40	ST203M-B40			
50	ST201M-B50NA	50	ST203M-B50			
60	ST201M-B60NA	60	ST203M-B60			
63	ST201M-B63NA	63	ST203M-B63			

Diagram

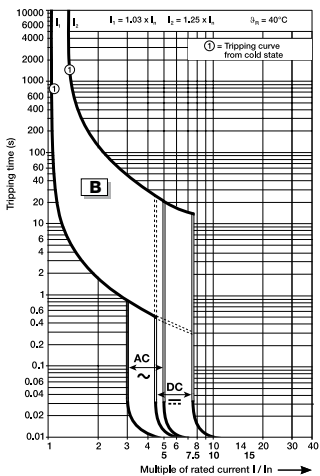



ST200M-B (cont.)

Supplemental protectors — UL 1077, CSA 22.2 No. 235

Number of poles	Rated current		Number of poles	Rated current	
	I_n A	Cat. no.		I_n A	Cat. no.
3+NA	0.5	ST203M-B0.5NA	4	0.5	ST204M-B0.5
	1	ST203M-B1NA		1	ST204M-B1
	1.6	ST203M-B1.6NA		1.6	ST204M-B1.6
	2	ST203M-B2NA		2	ST204M-B2
	3	ST203M-B3NA		3	ST204M-B3
	4	ST203M-B4NA		4	ST204M-B4
	5	ST203M-B5NA		5	ST204M-B5
	6	ST203M-B6NA		6	ST204M-B6
	7	ST203M-B7NA		7	ST204M-B7
	8	ST203M-B8NA		8	ST204M-B8
	10	ST203M-B10NA		10	ST204M-B10
	13	ST203M-B13NA		13	ST204M-B13
	15	ST203M-B15NA		15	ST204M-B15
	16	ST203M-B16NA		16	ST204M-B16
	20	ST203M-B20NA		20	ST204M-B20
	25	ST203M-B25NA		25	ST204M-B25
	30	ST203M-B30NA		30	ST204M-B30
	32	ST203M-B32NA		32	ST204M-B32
	35	ST203M-B35NA		35	ST204M-B35
	40	ST203M-B40NA		40	ST204M-B40
	50	ST203M-B50NA		50	ST204M-B50
	60	ST203M-B60NA		60	ST204M-B60
	63	ST203M-B63NA		63	ST204M-B63

ST200M-C

Supplemental protectors — UL 1077, CSA 22.2 No. 235

	Number of poles	Rated current		Number of poles	Rated current				
		I_n A	Cat. no.		I_n A	Cat. no.			
	1	0.5	ST201M-C0.5	2	0.5	ST202M-C0.5			
		1	ST201M-C1		1	ST202M-C1			
		1.6	ST201M-C1.6		1.6	ST202M-C1.6			
		2	ST201M-C2		2	ST202M-C2			
		3	ST201M-C3		3	ST202M-C3			
		4	ST201M-C4		4	ST202M-C4			
		5	ST201M-C5		5	ST202M-C5			
		6	ST201M-C6		6	ST202M-C6			
		7	ST201M-C7		7	ST202M-C7			
		8	ST201M-C8		8	ST202M-C8			
		10	ST201M-C10		10	ST202M-C10			
		13	ST201M-C13		13	ST202M-C13			
		15	ST201M-C15		15	ST202M-C15			
		16	ST201M-C16		16	ST202M-C16			
		20	ST201M-C20		20	ST202M-C20			
		25	ST201M-C25		25	ST202M-C25			
		30	ST201M-C30		30	ST202M-C30			
			1+NA		0.5	ST201M-C0.5NA	3	0.5	ST203M-C0.5
					1	ST201M-C1NA		1	ST203M-C1
1.6	ST201M-C1.6NA			1.6	ST203M-C1.6				
2	ST201M-C2NA			2	ST203M-C2				
3	ST201M-C3NA			3	ST203M-C3				
4	ST201M-C4NA			4	ST203M-C4				
5	ST201M-C5NA			5	ST203M-C5				
6	ST201M-C6NA			6	ST203M-C6				
7	ST201M-C7NA			7	ST203M-C7				
8	ST201M-C8NA			8	ST203M-C8				
10	ST201M-C10NA			10	ST203M-C10				
13	ST201M-C13NA			13	ST203M-C13				
15	ST201M-C15NA			15	ST203M-C15				
16	ST201M-C16NA			16	ST203M-C16				
20	ST201M-C20NA			20	ST203M-BC20				
25	ST201M-C25NA			25	ST203M-C25				
30	ST201M-C30NA			30	ST203M-C30				
32	ST201M-C32NA			32	ST203M-C32				
35	ST201M-C35NA			35	ST203M-C35				
40	ST201M-C40NA	40	ST203M-C40						
50	ST201M-C50NA	50	ST203M-C50						
60	ST201M-C60NA	60	ST203M-C60						
63	ST201M-C63NA	63	ST203M-C63						

Diagram

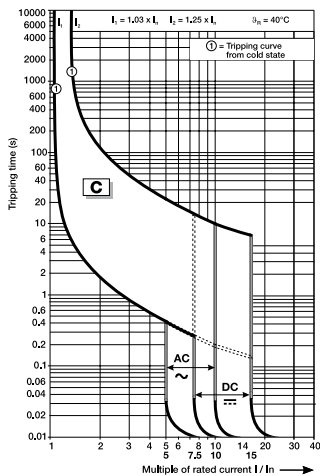



ST200M-C (cont.)

Supplemental protectors — UL 1077, CSA 22.2 No. 235

Number of poles	Rated current		Number of poles	Rated current	
	I_n A	Cat. no.		I_n A	Cat. no.
3+NA	0.5	ST203M-C0.5NA	4	0.5	ST204M-C0.5
	1	ST203M-C1NA		1	ST204M-C1
	1.6	ST203M-C1.6NA		1.6	ST204M-C1.6
	2	ST203M-C2NA		2	ST204M-C2
	3	ST203M-C3NA		3	ST204M-C3
	4	ST203M-C4NA		4	ST204M-C4
	5	ST203M-C5NA		5	ST204M-C5
	6	ST203M-C6NA		6	ST204M-C6
	7	ST203M-C7NA		7	ST204M-C7
	8	ST203M-C8NA		8	ST204M-C8
	10	ST203M-C10NA		10	ST204M-C10
	13	ST203M-C13NA		13	ST204M-C13
	15	ST203M-C15NA		15	ST204M-C15
	16	ST203M-C16NA		16	ST204M-C16
	20	ST203M-C20NA		20	ST204M-C20
	25	ST203M-C25NA		25	ST204M-C25
	30	ST203M-C30NA		30	ST204M-C30
	32	ST203M-C32NA		32	ST204M-C32
	35	ST203M-C35NA		35	ST204M-C35
	40	ST203M-C40NA		40	ST204M-C40
50	ST203M-C50NA	50	ST204M-C50		
60	ST203M-C60NA	60	ST204M-C60		
63	ST203M-C63NA	63	ST204M-C63		

ST200M-D

Supplemental protectors — UL 1077, CSA 22.2 No. 235

	Number of poles	Rated current		Cat. no.	Number of poles	Rated current				
		I_n A				I_n A	Cat. no.			
	1	0.5		ST201M-D0.5	2	0.5	ST202M-D0.5			
		1		ST201M-D1		1	ST202M-D1			
		1.6		ST201M-D1.6		1.6	ST202M-D1.6			
		2		ST201M-D2		2	ST202M-D2			
		3		ST201M-D3		3	ST202M-D3			
		4		ST201M-D4		4	ST202M-D4			
		5		ST201M-D5		5	ST202M-D5			
		6		ST201M-D6		6	ST202M-D6			
		7		ST201M-D7		7	ST202M-D7			
		8		ST201M-D8		8	ST202M-D8			
		10		ST201M-D10		10	ST202M-D10			
		13		ST201M-D13		13	ST202M-D13			
		15		ST201M-D15		15	ST202M-D15			
		16		ST201M-D16		16	ST202M-D16			
		20		ST201M-D20		20	ST202M-D20			
		25		ST201M-D25		25	ST202M-D25			
			1+NA	0.5			ST201M-D0.5NA	3	0.5	ST203M-D0.5
				1			ST201M-D1NA		1	ST203M-D1
1.6				ST201M-D1.6NA	1.6	ST203M-D1.6				
2				ST201M-D2NA	2	ST203M-D2				
3				ST201M-D3NA	3	ST203M-D3				
4				ST201M-D4NA	4	ST203M-D4				
5				ST201M-D5NA	5	ST203M-D5				
6				ST201M-D6NA	6	ST203M-D6				
7				ST201M-D7NA	7	ST203M-D7				
8				ST201M-D8NA	8	ST203M-D8				
10				ST201M-D10NA	10	ST203M-D10				
13				ST201M-D13NA	13	ST203M-D13				
15				ST201M-D15NA	15	ST203M-D15				
16				ST201M-D16NA	16	ST203M-D16				
20				ST201M-D20NA	20	ST203M-D20				
25				ST201M-D25NA	25	ST203M-D25				
30				ST201M-D30NA	30	ST203M-D30				
32				ST201M-D32NA	32	ST203M-D32				
35		ST201M-D35NA	35	ST203M-D35						
40		ST201M-D40NA	40	ST203M-D40						
50		ST201M-D50NA	50	ST203M-D50						
60		ST201M-D60NA	60	ST203M-D60						
63		ST201M-D63NA	63	ST203M-D63						

Diagram

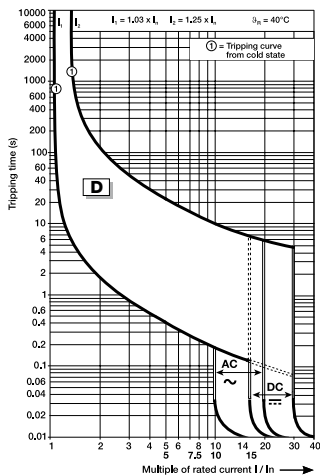



ST200M-D (cont.)

Supplemental protectors — UL 1077, CSA 22.2 No. 235

Number of poles	Rated current		Number of poles	Rated current	
	I_n A	Cat. no.		I_n A	Cat. no.
3+NA	0.5	ST203M-D0.5NA	4	0.5	ST204M-D0.5
	1	ST203M-D1NA		1	ST204M-D1
	1.6	ST203M-D1.6NA		1.6	ST204M-D1.6
	2	ST203M-D2NA		2	ST204M-D2
	3	ST203M-D3NA		3	ST204M-D3
	4	ST203M-D4NA		4	ST204M-D4
	5	ST203M-D5NA		5	ST204M-D5
	6	ST203M-D6NA		6	ST204M-D6
	7	ST203M-D7NA		7	ST204M-D7
	8	ST203M-D8NA		8	ST204M-D8
	10	ST203M-D10NA		10	ST204M-D10
	13	ST203M-D13NA		13	ST204M-D13
	15	ST203M-D15NA		15	ST204M-D15
	16	ST203M-D16NA		16	ST204M-D16
	20	ST203M-D20NA		20	ST204M-D20
	25	ST203M-D25NA		25	ST204M-D25
	30	ST203M-D30NA		30	ST204M-D30
	32	ST203M-D32NA		32	ST204M-D32
	35	ST203M-D35NA		35	ST204M-D35
	40	ST203M-D40NA		40	ST204M-D40
50	ST203M-D50NA	50	ST204M-D50		
60	ST203M-D60NA	60	ST204M-D60		
63	ST203M-D63NA	63	ST204M-D63		

ST200M-K

Supplemental protectors — UL 1077, CSA 22.2 No. 235

	Number of poles	Rated current		Cat. no.	Number of poles	Rated current	
		I_n A				I_n A	Cat. no.
	1	0.5		ST201M-K0.5	2	0.5	ST202M-K0.5
		1		ST201M-K1		1	ST202M-K1
		1.6		ST201M-K1.6		1.6	ST202M-K1.6
		2		ST201M-K2		2	ST202M-K2
		3		ST201M-K3		3	ST202M-K3
		4		ST201M-K4		4	ST202M-K4
		5		ST201M-K5		5	ST202M-K5
		6		ST201M-K6		6	ST202M-K6
		7		ST201M-K7		7	ST202M-K7
		8		ST201M-K8		8	ST202M-K8
		10		ST201M-K10		10	ST202M-K10
		13		ST201M-K13		13	ST202M-K13
		15		ST201M-K15		15	ST202M-K15
		16		ST201M-K16		16	ST202M-K16
		20		ST201M-K20		20	ST202M-K20
		25		ST201M-K25		25	ST202M-K25
		30		ST201M-K30		30	ST202M-K30
		32		ST201M-K32		32	ST202M-K32
		35		ST201M-K35		35	ST202M-K35
40		ST201M-K40	40	ST202M-K40			
50		ST201M-K50	50	ST202M-K50			
60		ST201M-K60	60	ST202M-K60			
63		ST201M-K63	63	ST202M-K63			
	1+NA	0.5		ST201M-K0.5NA	3	0.5	ST203M-K0.5
		1		ST201M-K1NA		1	ST203M-K1
		1.6		ST201M-K1.6NA		1.6	ST203M-K1.6
		2		ST201M-K2NA		2	ST203M-K2
		3		ST201M-K3NA		3	ST203M-K3
		4		ST201M-K4NA		4	ST203M-K4
		5		ST201M-K5NA		5	ST203M-K5
		6		ST201M-K6NA		6	ST203M-K6
		7		ST201M-K7NA		7	ST203M-K7
		8		ST201M-K8NA		8	ST203M-K8
		10		ST201M-K10NA		10	ST203M-K10
		13		ST201M-K13NA		13	ST203M-K13
		15		ST201M-K15NA		15	ST203M-K15
		16		ST201M-K16NA		16	ST203M-K16
		20		ST201M-K20NA		20	ST203M-K20
		25		ST201M-K25NA		25	ST203M-K25
		30		ST201M-K30NA		30	ST203M-K30
		32		ST201M-K32NA		32	ST203M-K32
		35		ST201M-K35NA		35	ST203M-K35
40		ST201M-K40NA	40	ST203M-K40			
50		ST201M-K50NA	50	ST203M-K50			
60		ST201M-K60NA	60	ST203M-K60			
63		ST201M-K63NA	63	ST203M-K63			

Diagram

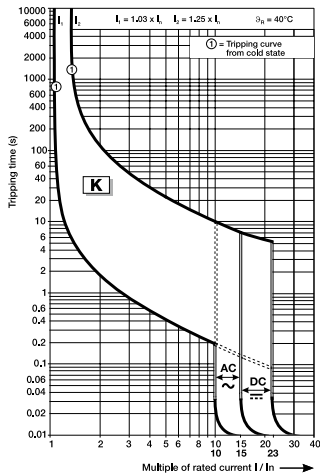

ST200M-K (cont.)

Supplemental protectors — UL 1077, CSA 22.2 No. 235

Number of poles	Rated current		Number of poles	Rated current	
	I_n A	Cat. no.		I_n A	Cat. no.
3+NA	0.5	ST203M-K0.5NA	4	0.5	ST204M-K0.5
	1	ST203M-K1NA		1	ST204M-K1
	1.6	ST203M-K1.6NA		1.6	ST204M-K1.6
	2	ST203M-K2NA		2	ST204M-K2
	3	ST203M-K3NA		3	ST204M-K3
	4	ST203M-K4NA		4	ST204M-K4
	5	ST203M-K5NA		5	ST204M-K5
	6	ST203M-K6NA		6	ST204M-K6
	7	ST203M-K7NA		7	ST204M-K7
	8	ST203M-K8NA		8	ST204M-K8
	10	ST203M-K10NA		10	ST204M-K10
	13	ST203M-K13NA		13	ST204M-K13
	15	ST203M-K15NA		15	ST204M-K15
	16	ST203M-K16NA		16	ST204M-K16
	20	ST203M-K20NA		20	ST204M-K20
	25	ST203M-K25NA		25	ST204M-K25
	30	ST203M-K30NA		30	ST204M-K30
	32	ST203M-K32NA		32	ST204M-K32
	35	ST203M-K35NA		35	ST204M-K35
	40	ST203M-K40NA		40	ST204M-K40
50	ST203M-K50NA	50	ST204M-K50		
60	ST203M-K60NA	60	ST204M-K60		
63	ST203M-K63NA	63	ST204M-K63		

ST200M-Z

Supplemental protectors — UL 1077, CSA 22.2 No. 235

	Number of poles	Rated current		Cat. no.	Number of poles	Rated current	
		I_n A				I_n A	Cat. no.
	1	0.5		ST201M-Z0.5	2	0.5	ST202M-Z0.5
		1		ST201M-Z1		1	ST202M-Z1
		1.6		ST201M-Z1.6		1.6	ST202M-Z1.6
		2		ST201M-Z2		2	ST202M-Z2
		3		ST201M-Z3		3	ST202M-Z3
		4		ST201M-Z4		4	ST202M-Z4
		5		ST201M-Z5		5	ST202M-Z5
		6		ST201M-Z6		6	ST202M-Z6
		7		ST201M-Z7		7	ST202M-Z7
		8		ST201M-Z8		8	ST202M-Z8
		10		ST201M-Z10		10	ST202M-Z10
		13		ST201M-Z13		13	ST202M-Z13
		15		ST201M-Z15		15	ST202M-Z15
		16		ST201M-Z16		16	ST202M-Z16
		20		ST201M-Z20		20	ST202M-Z20
		25		ST201M-Z25		25	ST202M-Z25
		30		ST201M-Z30		30	ST202M-Z30
		32		ST201M-Z32		32	ST202M-Z32
		35		ST201M-Z35		35	ST202M-Z35
40		ST201M-Z40	40	ST202M-Z40			
50		ST201M-Z50	50	ST202M-Z50			
60		ST201M-Z60	60	ST202M-Z60			
63		ST201M-Z63	63	ST202M-Z63			
	1+NA	0.5		ST201M-Z0.5NA	3	0.5	ST203M-Z0.5
		1		ST201M-Z1NA		1	ST203M-Z1
		1.6		ST201M-Z1.6NA		1.6	ST203M-Z1.6
		2		ST201M-Z2NA		2	ST203M-Z2
		3		ST201M-Z3NA		3	ST203M-Z3
		4		ST201M-Z4NA		4	ST203M-Z4
		5		ST201M-Z5NA		5	ST203M-Z5
		6		ST201M-Z6NA		6	ST203M-Z6
		7		ST201M-Z7NA		7	ST203M-Z7
		8		ST201M-Z8NA		8	ST203M-Z8
		10		ST201M-Z10NA		10	ST203M-Z10
		13		ST201M-Z13NA		13	ST203M-Z13
		15		ST201M-Z15NA		15	ST203M-Z15
		16		ST201M-Z16NA		16	ST203M-Z16
		20		ST201M-Z20NA		20	ST203M-Z20
		25		ST201M-Z25NA		25	ST203M-Z25
		30		ST201M-Z30NA		30	ST203M-Z30
		32		ST201M-Z32NA		32	ST203M-Z32
		35		ST201M-Z35NA		35	ST203M-Z35
40		ST201M-Z40NA	40	ST203M-Z40			
50		ST201M-Z50NA	50	ST203M-Z50			
60		ST201M-Z60NA	60	ST203M-Z60			
63		ST201M-Z63NA	63	ST203M-Z63			

Diagram

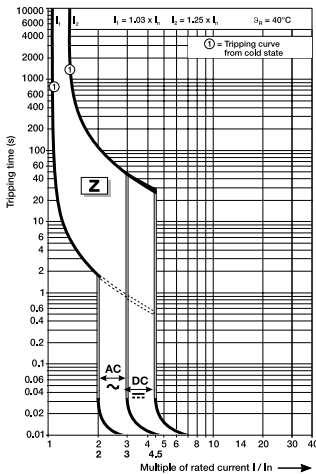

ST200M-Z (cont.)

Supplemental protectors — UL 1077, CSA 22.2 No. 235

Number of poles	Rated current		Number of poles	Rated current	
	I_n A	Cat. no.		I_n A	Cat. no.
3+NA	0.5	ST203M-Z0.5NA	4	0.5	ST204M-Z0.5
	1	ST203M-Z1NA		1	ST204M-Z1
	1.6	ST203M-Z1.6NA		1.6	ST204M-Z1.6
	2	ST203M-Z2NA		2	ST204M-Z2
	3	ST203M-Z3NA		3	ST204M-Z3
	4	ST203M-Z4NA		4	ST204M-Z4
	5	ST203M-Z5NA		5	ST204M-Z5
	6	ST203M-Z6NA		6	ST204M-Z6
	7	ST203M-Z7NA		7	ST204M-Z7
	8	ST203M-Z8NA		8	ST204M-Z8
	10	ST203M-Z10NA		10	ST204M-Z10
	13	ST203M-Z13NA		13	ST204M-Z13
	15	ST203M-Z15NA		15	ST204M-Z15
	16	ST203M-Z16NA		16	ST204M-Z16
	20	ST203M-Z20NA		20	ST204M-Z20
	25	ST203M-Z25NA		25	ST204M-Z25
	30	ST203M-Z30NA		30	ST204M-Z30
	32	ST203M-Z32NA		32	ST204M-Z32
	35	ST203M-Z35NA		35	ST204M-Z35
	40	ST203M-Z40NA		40	ST204M-Z40
50	ST203M-Z50NA	50	ST204M-Z50		
60	ST203M-Z60NA	60	ST204M-Z60		
63	ST203M-Z63NA	63	ST204M-Z63		

S200MR-K with ring tongue terminals

Supplemental protectors — UL 1077, CSA 22.2 No. 235

Number of poles	Rated current		Number of poles	Rated current	
	I_n A	Cat. no.		I_n A	Cat. no.
1	0.2	S201MR-K0.2	3	0.2	S203MR-K0.2
	0.3	S201MR-K0.3		0.3	S203MR-K0.3
	0.5	S201MR-K0.5		0.5	S203MR-K0.5
	0.75	S201MR-K0.75		0.75	S203MR-K0.75
	1	S201MR-K1		1	S203MR-K1
	1.6	S201MR-K1.6		1.6	S203MR-K1.6
	2	S201MR-K2		2	S203MR-K2
	3	S201MR-K3		3	S203MR-K3
	4	S201MR-K4		4	S203MR-K4
	5	S201MR-K5		5	S203MR-K5
	6	S201MR-K6		6	S203MR-K6
	8	S201MR-K8		8	S203MR-K8
	10	S201MR-K10		10	S203MR-K10
	13	S201MR-K13		13	S203MR-K13
	15	S201MR-K15		15	S203MR-K15
	16	S201MR-K16		16	S203MR-K16
20	S201MR-K20	20	S203MR-K20		
25	S201MR-K25	25	S203MR-K25		
30	S201MR-K30	30	S203MR-K30		
32	S201MR-K32	32	S203MR-K32		
35	S201MR-K35	35	S203MR-K35		
40	S201MR-K40	40	S203MR-K40		
50	S201MR-K50	50	S203MR-K50		
60	S201MR-K60	60	S203MR-K60		
63	S201MR-K63	63	S203MR-K63		
2	0.2	S202MR-K0.2	4	0.2	S204MR-K0.2
	0.3	S202MR-K0.3		0.3	S204MR-K0.3
	0.5	S202MR-K0.5		0.5	S204MR-K0.5
	0.75	S202MR-K0.75		0.75	S204MR-K0.75
	1	S202MR-K1		1	S204MR-K1
	1.6	S202MR-K1.6		1.6	S204MR-K1.6
	2	S202MR-K2		2	S204MR-K2
	3	S202MR-K3		3	S204MR-K3
	4	S202MR-K4		4	S204MR-K4
	5	S202MR-K5		5	S204MR-K5
	6	S202MR-K6		6	S204MR-K6
	8	S202MR-K8		8	S204MR-K8
	10	S202MR-K10		10	S204MR-K10
	13	S202MR-K13		13	S204MR-K13
	15	S202MR-K15		15	S204MR-K15
	16	S202MR-K16		16	S204MR-K16
20	S202MR-K20	20	S204MR-K20		
25	S202MR-K25	25	S204MR-K25		
30	S202MR-K30	30	S204MR-K30		
32	S202MR-K32	32	S204MR-K32		
35	S202MR-K35	35	S204MR-K35		
40	S202MR-K40	40	S204MR-K40		
50	S202MR-K50	50	S204MR-K50		
60	S202MR-K60	60	S204MR-K60		
63	S202MR-K63	63	S204MR-K63		

Diagram

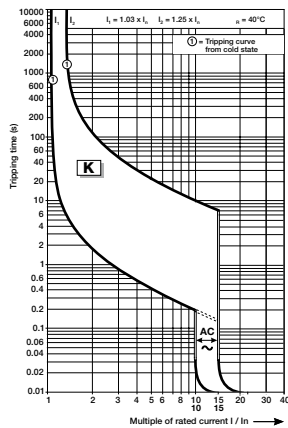

S200MUC-C

Supplemental protectors — UL 1077, CSA 22.2 No. 235

Number of poles	Rated current		Number of poles	Rated current	
	I_n A	Cat. no.		I_n A	Cat. no.
1	0.5	S201MUC-C0.5	3	0.5	S203MUC-C0.5
	1	S201MUC-C1		1	S203MUC-C1
	1.6	S201MUC-C1.6		1.6	S203MUC-C1.6
	2	S201MUC-C2		2	S203MUC-C2
	3	S201MUC-C3		3	S203MUC-C3
	4	S201MUC-C4		4	S203MUC-C4
	6	S201MUC-C6		6	S203MUC-C6
	8	S201MUC-C8		8	S203MUC-C8
	10	S201MUC-C10		10	S203MUC-C10
	13	S201MUC-C13		13	S203MUC-C13
	16	S201MUC-C16		16	S203MUC-C16
	20	S201MUC-C20		20	S203MUC-C20
	25	S201MUC-C25		25	S203MUC-C25
	32	S201MUC-C32		32	S203MUC-C32
2	0.5	S202MUC-C0.5	4	0.5	S204MUC-C0.5
	1	S202MUC-C1		1	S204MUC-C1
	1.6	S202MUC-C1.6		1.6	S204MUC-C1.6
	2	S202MUC-C2		2	S204MUC-C2
	3	S202MUC-C3		3	S204MUC-C3
	4	S202MUC-C4		4	S204MUC-C4
	6	S202MUC-C6		6	S204MUC-C6
	8	S202MUC-C8		8	S204MUC-C8
	10	S202MUC-C10		10	S204MUC-C10
	13	S202MUC-C13		13	S204MUC-C13
	16	S202MUC-C16		16	S204MUC-C16
	20	S202MUC-C20		20	S204MUC-C20
	25	S202MUC-C25		25	S204MUC-C25
	32	S202MUC-C32		32	S204MUC-C32
40	S202MUC-C40	40	S204MUC-C40		
50	S202MUC-C50	50	S204MUC-C50		
63	S202MUC-C63	63	S204MUC-C63		



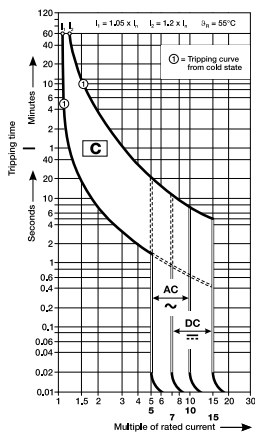

Diagram



S200MUC-K

Supplemental protectors — UL 1077, CSA 22.2 No. 235

	Rated current			Rated current		
	Number of poles	I_n A	Cat. no.	Number of poles	I_n A	Cat. no.
	1	0.2	S201MUC-K0.2	3	0.2	S203MUC-K0.2
		0.3	S201MUC-K0.3		0.3	S203MUC-K0.3
		0.5	S201MUC-K0.5		0.5	S203MUC-K0.5
		0.75	S201MUC-K0.75		0.75	S203MUC-K0.75
		1	S201MUC-K1		1	S203MUC-K1
		1.6	S201MUC-K1.6		1.6	S203MUC-K1.6
		2	S201MUC-K2		2	S203MUC-K2
		3	S201MUC-K3		3	S203MUC-K3
		4	S201MUC-K4		4	S203MUC-K4
		5	S201MUC-K5		5	S203MUC-K5
		6	S201MUC-K6		6	S203MUC-K6
		8	S201MUC-K8		8	S203MUC-K8
		10	S201MUC-K10		10	S203MUC-K10
		13	S201MUC-K13		13	S203MUC-K13
		15	S201MUC-K15		15	S203MUC-K15
		16	S201MUC-K16		16	S203MUC-K16
		20	S201MUC-K20		20	S203MUC-K20
		25	S201MUC-K25		25	S203MUC-K25
		30	S201MUC-K30		30	S203MUC-K30
32	S201MUC-K32	32	S203MUC-K32			
35	S201MUC-K35	35	S203MUC-K35			
40	S201MUC-K40	40	S203MUC-K40			
50	S201MUC-K50	50	S203MUC-K50			
60	S201MUC-K60	60	S203MUC-K60			
63	S201MUC-K63	63	S203MUC-K63			
	2	0.2	S202MUC-K0.2	4	0.2	S204MUC-K0.2
		0.3	S202MUC-K0.3		0.3	S204MUC-K0.3
		0.5	S202MUC-K0.5		0.5	S204MUC-K0.5
		0.75	S202MUC-K0.75		0.75	S204MUC-K0.75
		1	S202MUC-K1		1	S204MUC-K1
		1.6	S202MUC-K1.6		1.6	S204MUC-K1.6
		2	S202MUC-K2		2	S204MUC-K2
		3	S202MUC-K3		3	S204MUC-K3
		4	S202MUC-K4		4	S204MUC-K4
		5	S202MUC-K5		5	S204MUC-K5
		6	S202MUC-K6		6	S204MUC-K6
		8	S202MUC-K8		8	S204MUC-K8
		10	S202MUC-K10		10	S204MUC-K10
		13	S202MUC-K13		13	S204MUC-K13
		15	S202MUC-K15		15	S204MUC-K15
		16	S202MUC-K16		16	S204MUC-K16
		20	S202MUC-K20		20	S204MUC-K20
		25	S202MUC-K25		25	S204MUC-K25
		30	S202MUC-K30		30	S204MUC-K30
32	S202MUC-K32	32	S204MUC-K32			
35	S202MUC-K35	35	S204MUC-K35			
40	S202MUC-K40	40	S204MUC-K40			
50	S202MUC-K50	50	S204MUC-K50			
60	S202MUC-K60	60	S204MUC-K60			
63	S202MUC-K63	63	S204MUC-K63			

Diagram

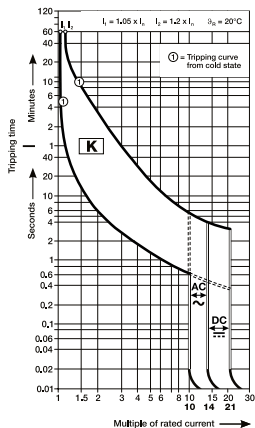

S200MUC-Z

Supplemental protectors — UL 1077, CSA 22.2 No. 235

Number of poles	Rated current		Number of poles	Rated current	
	I_n A	Cat. no.		I_n A	Cat. no.
1	0.5	S201MUC-Z0.5	3	0.5	S203MUC-Z0.5
	1	S201MUC-Z1		1	S203MUC-Z1
	1.6	S201MUC-Z1.6		1.6	S203MUC-Z1.6
	2	S201MUC-Z2		2	S203MUC-Z2
	3	S201MUC-Z3		3	S203MUC-Z3
	4	S201MUC-Z4		4	S203MUC-Z4
	5	S201MUC-Z5		5	S203MUC-Z5
	6	S201MUC-Z6		6	S203MUC-Z6
	8	S201MUC-Z8		8	S203MUC-Z8
	10	S201MUC-Z10		10	S203MUC-Z10
	15	S201MUC-Z15		15	S203MUC-Z15
	16	S201MUC-Z16		16	S203MUC-Z16
	20	S201MUC-Z20		20	S203MUC-Z20
	25	S201MUC-Z25		25	S203MUC-Z25
	30	S201MUC-Z30		30	S203MUC-Z30
	2	0.5		S202MUC-Z0.5	4
1		S202MUC-Z1	1	S204MUC-Z1	
1.6		S202MUC-Z1.6	1.6	S204MUC-Z1.6	
2		S202MUC-Z2	2	S204MUC-Z2	
3		S202MUC-Z3	3	S204MUC-Z3	
4		S202MUC-Z4	4	S204MUC-Z4	
5		S202MUC-Z5	5	S204MUC-Z5	
6		S202MUC-Z6	6	S204MUC-Z6	
8		S202MUC-Z8	8	S204MUC-Z8	
10		S202MUC-Z10	10	S204MUC-Z10	
15		S202MUC-Z15	15	S204MUC-Z15	
16		S202MUC-Z16	16	S204MUC-Z16	
20		S202MUC-Z20	20	S204MUC-Z20	
25		S202MUC-Z25	25	S204MUC-Z25	
30		S202MUC-Z30	30	S204MUC-Z30	
		32	S202MUC-Z32	32	
	35	S202MUC-Z35	35	S204MUC-Z35	
	40	S202MUC-Z40	40	S204MUC-Z40	
	50	S202MUC-Z50	50	S204MUC-Z50	
	60	S202MUC-Z60	60	S204MUC-Z60	
	63	S202MUC-Z63	63	S204MUC-Z63	

Diagram

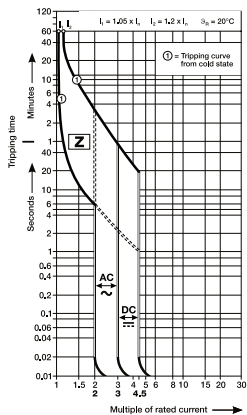

Accessories

ST200M, S200MR and S200MUC — UL 1077, CSA 22.2 No. 235

Auxiliary contacts

The auxiliary contacts will signal whether the breaker is in the ON or OFF position.

	Description	Cat. no.
For field mounting: right side		
	Auxiliary contact 1 CO	S2C-H6R
	Auxiliary contact 1 NO/1 NC	S2C-H6-11R
	Auxiliary contact 2 NO	S2C-H6-20R
	Auxiliary contact 2 NC	S2C-H6-02R

Bell alarm — signal contact

The bell alarm includes a set of contacts that will only signal when the breaker has tripped. Typically, the contacts would be connected to an alarm or bell to signal the operator that an over-current trip has occurred. The bell alarm also includes a test button for testing the alarm contacts without opening the breaker.

	Description	Cat. no.
	For field mounting: right side	S2C-S/H6R

Shunt trip

For remote tripping of breaker, a shunt trip device can be added to the MCB. The solenoid device opens the breaker after control voltage is applied.



	Description	Cat. no.
For field mounting: right side		
	A1-12-60 V AC (12–60 V DC)	S2C-A1
	A2-110-415 V AC (110–250 V DC)	S2C-A2

Undervoltage release

When control voltage drops below approximately 50 percent of rated voltage, the UVR opens the breaker. The breaker can not be operated unless proper control voltage is first applied to the UVR coil.

	Description	Cat. no.
For field mounting: right side		
	12 V DC	S2C-UA12DC
	24 V AC or V DC	S2C-UA24AC or S2C-UA24DC
	48 V AC or V DC	S2C-UA48AC or S2C-UA48DC
	110 V AC or V DC	S2C-UA110AC or S2C-UA110DC
	230 V AC or V DC	S2C-UA230AC or S2C-UA230DC
	400 V AC	S2C-UA400AC

Locking device

	Description	Cat. no.
	Locking device, 3 mm	SA1
	Padlock with two keys	SA2

Bottom-fitted auxiliary contact

	Description	Cat. no.
	Auxiliary contact 1 NC	S2C-H01
	Auxiliary contact 1 NO	S2C-H10

Accessories

ST200M, S200MUC and S200MR — UL 1077, CSA 22.2 No. 235

Accessory overview

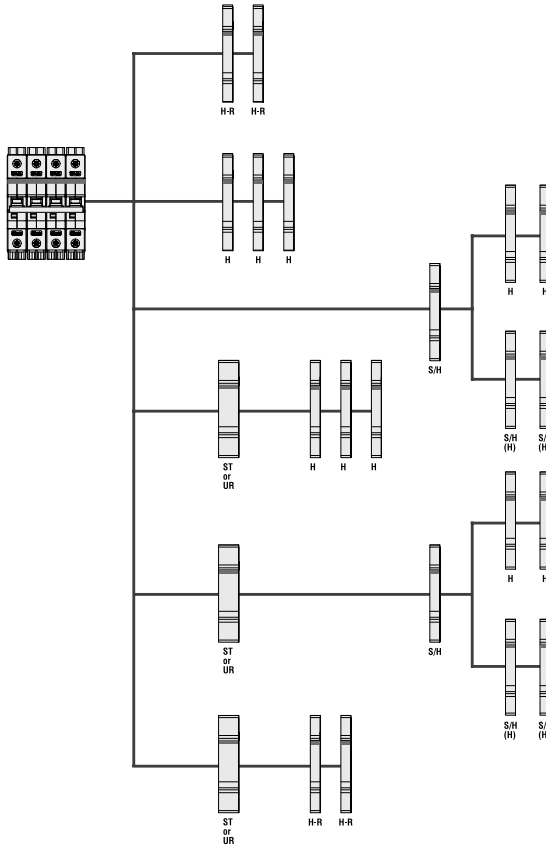

- H Auxiliary contact S2C-H6R
- H-R Auxiliary contact S2C-H6-...R
- S/H Signal/auxiliary contact S2C-S/H6R
- S/H (H) Signal/auxiliary contact S2C-S/H6R used as auxiliary contact
- ST Shunt trip S2C-A...
- UR Under-voltage release S2C-UA

SU200MR Instructions for use

Ring Tongue Terminal, Special purpose - Not for general use

Installation Instructions

Please insert or withdraw the cable lug only when the screw is completely open.

Please make sure that the terminal screw penetrates the ring lug hole properly and completely during tightening.

Please ensure that the screw is securely tightened before applying any mechanical force on the cable / cable lug.

Do not apply abnormal downward pressure on the screw during tightening or loosening of the screw.

$F = \text{max. } 30 \text{ N}$ $F = \text{Maximum to operate}$

Please follow the Ring Tongue Details on the rear of this sheet.

Ring Tongue Details

Only or ring cable lugs	Insulated only 	A	B	C
	Rated voltage 480Y/277 V AC	max. 11.0 mm (0.43")	max. 12.2 mm (0.48")	Suitable for M5 (0.20")
Rated voltage 240/240 V AC	Insulated only 	A	B	C
		max. 14.0 mm (0.55")	max. 12.2 mm (0.48")	Suitable for M5 (0.20")

CU only
 60/75°C
 (140/167°F)

max. 2.0 mm
 (0.08")

PZ 2 Torque: 2.8 Nm (25lb-in)

Accessories

ST200M and S200MUC UL 1077, CSA 22.2 No. 235 (suitable for cutting)

— Busbars (suitable for cutting) UL 1077, suitable for MCBs S200 and S200P

Number of pins	Phases	mm ²	Cat. no.
1-phase busbars, pin distance 17.6 mm, end caps PS-END 0			
60	1	10	PS 1/60 SP
60	1	16	PS 1/60/16 SP
1-phase busbars, connection of 1-pole devices with auxiliary, PS-END 0			
38	1	10	PS 1/38H SP
38	1	16	PS 1/38/16H SP
2-phase busbars, pin distance 17.6 mm, end caps PS-END SP			
58	2	10	PS 2/58 SP
58	2	16	PS 2/58/16 SP
2-phase busbars, connection of 2-pole devices with auxiliary, end caps PS-END SP			
48	2	16	PS 2/48/16 HSP
3-phase busbars, pin distance 17.6 mm, end caps PS-END SP			
60	3	10	PS 3/60 SP
60	3	16	PS 3/60/16 SP
3-phase busbars, connection of 3-pole devices with auxiliary, end caps PS-END SP			
48	3	16	PS 3/48/16 HSP
4-phase busbars, pin distance 17.6 mm, PS-END 1 SP			
60	4	16	PS 4/60/16 SP
4-phase busbars, connection of 4-pole devices with auxiliary, end caps PS-END 1 SP			
52	4	16	PS 4/52/16H SP
4-phase busbars, connection of 1+N and RCBO, end caps PS-END 1 SP			
58	4	16	PS4/58/16N SP
Shock-protection caps for PS...SP (UL 1077)			
—	5 parts	—	BSK SP

— Feeder terminals for PS...SP (UL 1077)

Terminal, insulated with pin contact	
Conn. capacity mm ²	Cat. no.
35	AST 35/15 SP

— Feeder terminal single-pole terminal, can be mounted side by side, feed on the pin of the busbar

Conn. capacity mm ²	Cat. no.
50	SZ-ESK SP

— Suitable for MCBs S 200 and S200 P - UL 1077 (supplementary protectors)

Technical specifications	Feeder terminals SZ-ESK SP, AST 35/15 SP	
Max. operating voltage	480 V AC	
Max. current	115 A ¹⁾	
Protection degree	IP20	
Wire range	SZ-ESK SP:	35 mm ² / 2 AWG flexible with ferrule
		50 mm ² / 1 AWG solid/stranded
	AST 35/15 SP:	25 mm ² / 3 AWG flexible with ferrule
		35 mm ² / 2 AWG solid/stranded

¹⁾ Regardless of the rated current of the feeder terminal, the maximum current rating of the device terminal.

Technical specifications

ST200M, S200MR, S200MUC — UL 1077, CSA 22.2 No. 235

Technical specifications

	ST200M	S200MR	S200MUC
Number of poles	1, 2, 3, 4	1, 2, 3, 4	1, 2, 3, 4
Trip curves	B, C, D, K, Z	K	C, K, Z
Rated current	0.5–63 A	0.2–63 A	0.2–63 A
Rated voltage	277/Y480 V AC 60/125 V DC (1/2-pole)	277/Y480 V AC	277/Y480 V AC 250/500 V DC (1/2-pole)
Short circuit interrupt rating	10 kA at 480Y/277 V AC (up to 32 A) 5 kA at 480Y/277 V AC (35 to 63 A) 10 kA at 240 V AC, 60/125 V DC	10 kA	10 kA (DC) 6 kA (AC)
Calibration temperature	40 °C	25 °C	25 °C
Protection degree	IP20	IP20	IP20
Mounting position	Any	Any	Any
Mounting/installation	35 mm DIN rail	35 mm DIN rail	35 mm DIN rail
Terminal/cable size	18–4 AWG	18–4 AWG	18–4 AWG
Service life, mechanical	20,000 operations	20,000 operations	20,000 operations
Ambient temperature	-25 °C to 55 °C	-25 °C to 55 °C	-25 °C to 55 °C
Shock resistance (IEC 60068-2-27)	25 g - 2 shocks - 13 ms	25 g - 2 shocks - 13 ms	25 g - 2 shocks - 13 ms

Auxiliary contact S2C-H6R and signal contact S2C-S6R

Rated current (A)	10
Rated voltage V AC/DC	24
Contact	1 pole, single throw
Connection capacity	18–14 AWG (0.75–2.5 mm ²)
Tightening torque	11 in. lbs (1.2 Nm)
Shock resistance acc. to DIN IEC 68-2-6	5 g, 20 frequency cycles 5...150...5 Hz at 24 V AC/DC, 5 mA auto-reclosing < 10 ms
Mechanical service life	10,000 operations

Technical specifications

ST200M, S200MR, S200MUC — UL 1077, CSA 22.2 No. 235

Shunt trip

	S2C-A1	S2C-A2
Rated voltage	12–60 V AC	110–415 V
	12–60 V DC	110–250 V
Maximum release duration	<10 ms	<10 ms
Minimum release voltage	7 V AC	55 V AC
	10 V DC	80 V DC
Consumption on release	40–200 VA AC	55–210 VA AC
	40–200 VA DC	55–110 VA DC
Coil resistance	3.7 V	225 V
Terminals	18–6 AWG/0.75–16 mm ²	18–6 AWG/0.75–16 mm ²
Tightening torque	18/2 in. lbs/Nm	18/2 in. lbs/Nm

Under-voltage release

	S2C-UA 12 DC	S2C-UA 24 AC	S2C-UA 24 DC	S2C-UA 48 AC	S2C-UA 48 DC	S2C-UA 110 AC	S2C-UA 110 DC	S2C-UA 230 AC	S2C-UA 230 DC	S2C-UA 400 AC
Standards	IEC/EN 60947-1110...415 V									
Rated voltage	AC	24 V		48 V		110 V		230 AC		400 V
	DC	12 V		24 V		48 V		110 V		230 V
Frequency	50 ... 60 HZ									
Release trip	0.35 UnOVO 0.7 Un V									
Terminals	2 x 16 AWG/2 x 1.5 mm ²									
Consumption	0.2 VA	3.6 VA	2 VA	3.6 VA	2.1 VA	3.5 VA	2.2 VA	3.7 VA	2.3 VA	2.4 VA
Resistance to corrosion	Constant atmosphere: 23/83 – 40/93 – 55/20; variable atmosphere: 25/95 – 40/93 °C/RH									
Protection degree	IPXXB / IP2X									
Tightening torque	3.5 lbs./0.4 in. Nm									

Technical specifications

ST200M and S200MR — UL 1077, CSA 22.2 No. 235

Internal resistance and power loss per pole

Internal resistance per pole in mV, power loss per pole in W.

ST200M internal resistance and power loss per pole

Rated current I_n [A]	B. C. K		D		Z	
	Internal resistance per pole R_i [mOhm]	Power loss P_v [W]	Internal resistance per pole R_i	Power loss P_v	Internal resistance per pole R_i	Power loss P_v
0.5	5500	1.4	4300	1.1	8100	2.4
1	1440	1.4	1250	1.25	2100	2.3
1.6	645	1.8	600	1.5	1000	2.8
2	460	1.8	410	1.7	620	2.5
3	150	1.6	130	1.2	235	2.4
4	110	1.8	105	1.7	150	2.4
5	55	1.4	52	1.3	75	1.9
6	55	2.0	52	1.9	75	3.2
7	24	1.2	26	1.3	28	1.4
8	23	1.5	24	1.5	27	2.0
10	21	2.2	16	1.6	24	2.7
13	14	2.3	14	2.2	15	2.6
15	8.5	2	8.5	2	11	2.5
16	8.5	2.5	8.5	2.5	10.9	2.8
20	6.25	2.5	6.1	2.3	6.0	2.4
25	5.0	3.2	4.3	3.1	4.5	3.3
30	3.5	3.1	3.5	3.2	3.5	3.2
32	3.5	3.7	3.5	3.6	3.5	3.6
35	3.4	4.2	3.4	4.2	3.5	4.3
40	3.0	4.8	2.2	4.2	2.5	4.1
50	1.8	4.3	1.3	2.9	1.5	4.1
60	1.2	4.4	1.2	4.4	1.3	4.7
63	1.2	5.5	1.2	4.8	1.3	5.2

S200MR internal resistance and power loss per pole

Rated current	Internal resistance per pole	Power loss per pole	Rated current	Internal resistance per pole	Power loss per pole
A	mΩ	W	A	mΩ	W
0.2	25300	1.01	13	14.8	2.50
0.3	13700	1.23	15	8.1	1.83
0.5	4740	1.19	16	11.1	2.83
0.75	2067	1.16	20	8.5	3.40
1	1270	1.27	25	5.5	3.43
1.5	610	1.56	30	3.8	3.39
2	442	1.77	32	4.6	4.70
3	140	1.26	35	3.9	4.76
4	109	1.75	40	2.8	4.40
5	50	1.26	50	1.7	4.25
6	54	1.94	60	1.7	6.18
8	22	1.41	63	1.9	7.56
10	18.2	1.82			

Technical specifications

ST200M and S200MR — UL 1077, CSA 22.2 No. 235

ST200M temperature rating

UL 1077 I_n (A)	Ambient temperature (°C)											
	-40	-30	-20	-10	0	10	20	30	40	50	60	70
0.5	0.65	0.63	0.61	0.59	0.57	0.56	0.54	0.52	0.50	0.48	0.46	0.44
1	1.30	1.26	1.22	1.19	1.15	1.11	1.07	1.04	1.00	0.96	0.93	0.89
1.6	2.06	2.01	1.96	1.90	1.84	1.78	1.72	1.66	1.60	1.54	1.48	1.42
2	2.60	2.52	2.44	2.37	2.30	2.22	2.15	2.07	2.00	1.93	1.85	1.78
3	3.89	3.78	3.67	3.56	3.44	3.33	3.22	3.11	3.00	2.89	2.78	2.67
4	5.19	5.04	4.89	4.74	4.59	4.44	4.30	4.15	4.00	3.85	3.70	3.56
5	6.50	6.31	6.13	5.94	5.75	5.56	5.38	5.00	5.00	4.81	4.63	4.44
6	7.77	7.55	7.33	7.11	6.89	6.67	6.44	6.22	6.00	5.78	5.56	5.33
7	9.10	8.84	8.58	8.31	8.05	7.79	7.53	7.00	7.00	6.74	6.48	6.21
8	10.36	10.07	9.78	9.48	9.18	8.89	8.59	8.30	8.00	7.70	7.41	7.11
10	13.00	12.60	12.20	11.90	11.50	11.10	10.70	10.40	10.00	9.60	9.30	8.90
13	16.90	16.40	15.90	15.40	14.90	14.40	14.00	13.50	13.00	12.50	12.00	11.60
15	19.50	18.94	18.38	17.81	17.25	16.69	16.13	16.00	15.00	14.44	13.88	13.31
16	20.60	20.10	19.60	19.00	18.40	17.80	17.20	16.60	16.00	15.40	14.80	14.20
20	26.00	25.20	24.40	23.70	23.00	22.20	21.50	20.70	20.00	19.30	18.50	17.80
25	32.40	31.50	30.60	29.60	28.70	27.80	26.90	25.90	25.00	24.10	23.20	22.20
30	39.00	37.88	36.75	35.63	34.50	33.38	32.25	31.00	30.00	28.88	27.75	26.63
32	41.50	40.30	39.10	37.90	36.70	35.60	34.40	33.20	32.00	30.80	29.60	28.40
35	47.00	45.30	43.70	42.10	40.60	39.10	37.70	36.30	35.00	33.70	32.50	31.30
40	51.90	50.40	48.90	47.40	45.90	44.40	43.00	41.50	40.00	38.50	37.00	35.60
50	64.90	63.00	61.10	59.30	57.40	55.60	53.70	51.90	50.00	48.20	46.30	44.50
60	80.50	77.60	74.80	72.10	69.50	67.00	64.60	62.30	60.00	57.80	55.70	53.70
63	81.60	79.30	77.00	74.70	72.30	70.00	67.70	65.30	63.00	60.70	58.30	56.00

S200MR temperature rating

B, C, D, K, and Z	Ambient temperatures T (C °/F °)											
	-40/-40	-30/-22	-20/-4	-10/14	0/32	10/50	20/68	30/86	40/104	50/122	60/140	70/158
Amps	0.67	0.65	0.62	0.60	0.58	0.55	0.53	0.50	0.47	0.44	0.41	0.37
	1.33	1.29	1.25	1.20	1.15	1.11	1.05	1.00	0.94	0.88	0.82	0.75
	2.13	2.07	2.00	1.92	1.85	1.77	1.69	1.60	1.51	1.41	1.31	1.19
	2.67	2.58	2.49	2.40	2.31	2.21	2.11	2.00	1.89	1.76	1.63	1.49
	4.0	3.9	3.7	3.6	3.5	3.3	3.2	3.0	2.8	2.6	2.4	2.2
	5.3	5.2	5.0	4.8	4.6	4.4	4.2	4.0	3.8	3.5	3.3	3.0
	8.0	7.7	7.5	7.2	6.9	6.6	6.3	6.0	5.7	5.3	4.9	4.5
	10.7	10.3	10.0	9.6	9.2	8.8	8.4	8.0	7.5	7.1	6.5	6.0
	13.3	12.9	12.5	12.0	11.5	11.1	10.5	10.0	9.4	8.8	8.2	7.5
	17.3	16.8	16.2	15.6	15.0	14.4	13.7	13.0	12.3	11.5	10.6	9.7
	21.3	20.7	20.0	19.2	18.5	17.7	16.9	16.0	15.1	14.1	13.1	11.9
	26.7	25.8	24.9	24.0	23.1	22.1	21.1	20.0	18.9	17.6	16.3	14.9
	33.3	32.3	31.2	30.0	28.9	27.6	26.4	25.0	23.6	22.0	20.4	18.6
	42.7	41.3	39.9	38.5	37.0	35.4	33.7	32.0	30.2	28.2	26.1	23.9
	53.3	51.6	49.9	48.1	46.2	44.2	42.2	40.0	37.7	35.3	32.7	29.8
	66.7	64.5	62.4	60.1	57.7	55.3	52.7	50.0	47.1	44.1	40.8	37.3
	84.0	81.3	78.6	75.7	72.7	69.6	66.4	63.0	59.4	55.6	51.4	47.0
	112.6	107.2	102.1	97.2	92.6	88.2	84.0	80.0	76.0	72.2	68.6	65.2
	140.7	134.0	127.6	121.6	115.8	110.3	105.0	100.0	95.0	90.3	85.7	81.5
	175.9	167.5	159.5	151.9	144.7	137.8	131.3	125.0	118.8	113.8	107.2	101.8

Temperature derating

Max. operating current depending on the ambient temperature.

Miniature circuit breaker S200MUC

Use of MCBs in direct current circuits

S200MUC miniature circuit breakers can be used in the 1-pole version at 250 V DC, and in the 2-pole or 4-pole version with series connection of two poles up to 500 V DC.

S200MUC differs from the standard S200 type. It is equipped with permanent magnets that assist in the forced extinguishing of the arc.

If voltages to ground exceeding 250 V DC occur, 2-pole S200MUC should be used for 1-pole disconnection and 4-pole S200MUC for all-pole disconnection.

For DC incoming supply from above

S200MUC MCBs have permanent magnets in the area of arc chutes. Therefore, it is necessary to take into account the polarity during the installation process. In the case of a short circuit, the magnetic field of the permanent magnets corresponds with the electromagnetic field of the short-circuit current, therefore, safely leading the short circuit into the arc chute. Incorrect polarities may cause damage to the MCB. As a result, for top-fed devices, terminal 1 must be connected to (-) and terminal 3 to (+).

Examples of permissible voltages between the conductors depending on the number of poles and circuit layout:

Voltage between conductors	U_n	250 V DC	500 V DC	500 V DC	500 V DC	500 V DC
Voltage between conductor and ground U_n		250 V DC	250 V DC	500 V DC	250 V DC	250 V DC
MCB		1-pole S201MUC	2-pole S202MUC	2-pole S202MUC	2-pole S202MUC	4-pole S204MUC
Supply from below						
						SK 0115 Z 94

Supply from above						
						SK 0114 Z 94

1 In the circuit diagram, the negative pole is earthed. 2 In the circuit diagram, the positive pole is earthed.

Examples of permissible voltages between the conductors depending on the number of poles and circuit layout:

Voltage between conductors	U_n	500 V DC all-pole disconnection	500 V DC 1-pole disconnection	500 V DC all-pole disconnection
Voltage between conductor and ground U_n		250 V DC circuit symmetrically grounded	250 V DC unsymmetrically grounded	250 V DC circuit ungrounded or unsymmetrically grounded
MCB		2-pole S202MUC	2-pole S202MUC	4-pole S204MUC
Supply from below				
				SK 0196 Z 98

1 In the circuit diagram, the negative pole is earthed. 2 In the circuit diagram, the positive pole is earthed.

Approximate dimensions

ST200M, S200MR and S200MUC — UL 1077, CSA 22.2 No. 235

ST200M, S200MUC

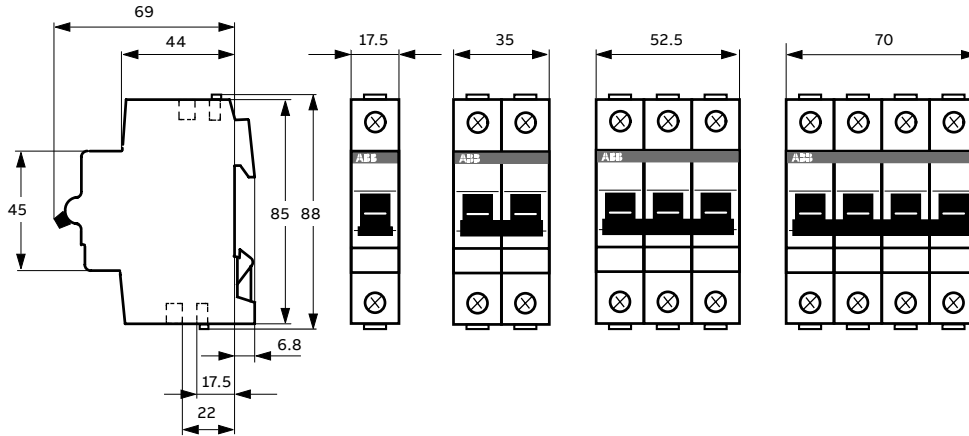

S200MR

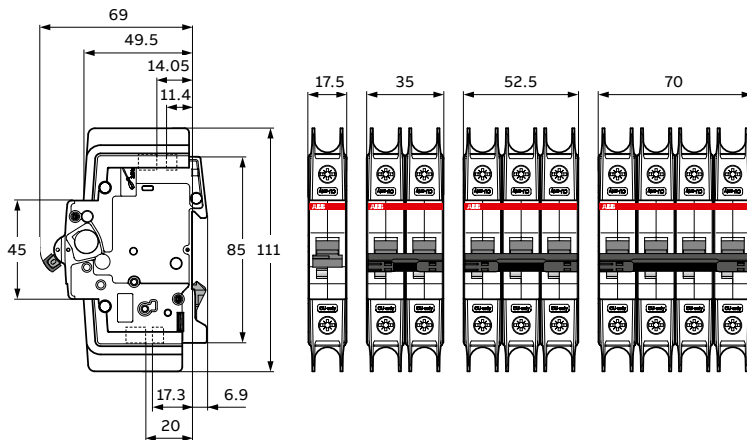

Application guide

Miniature circuit breaker

01 Thermal example:
The light draws more than 10 amps for an extended period of time, creating a thermal overload.

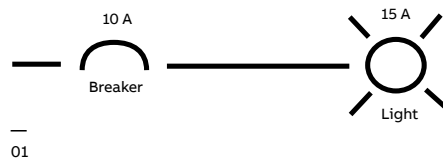

02 Magnetic example:
The wire connected between the light and breaker is cut and shorted to ground, creating a short circuit.

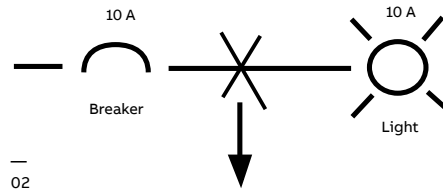

03 ABB current-limiting breaker

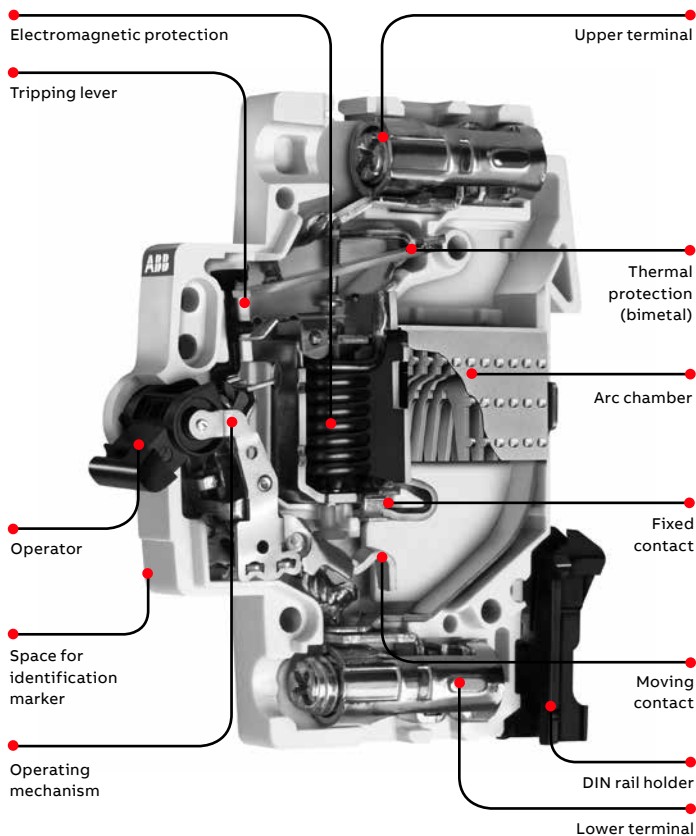

03

Introduction

The circuit breaker plays an important role in providing over-current protection and a disconnect means in electrical networks. Recent advancements in circuit breaker technology have increased breaker performance and protection.

Overload

An overload is a slow and small over-current situation that causes the ampacity and temperature of the circuit to gradually increase over time. This type of event is characterized by a slight increase in the load (ampacity) on the circuit and is interrupted by the thermal trip unit of the breaker.

Short circuit

A short circuit is a rapid and intense overcurrent situation that causes the ampacity of the circuit to increase. This type of event is characterized by a dramatic increase in the load (ampacity) on the circuit and is interrupted by the magnetic trip unit of the breaker.

Breaker definition

A breaker is a device designed to isolate a circuit during an over-current event without the use of a fusible element. A breaker is a resettable protective device that protects against two types of over-current situations: overload and short circuit.

Circuit breaker construction

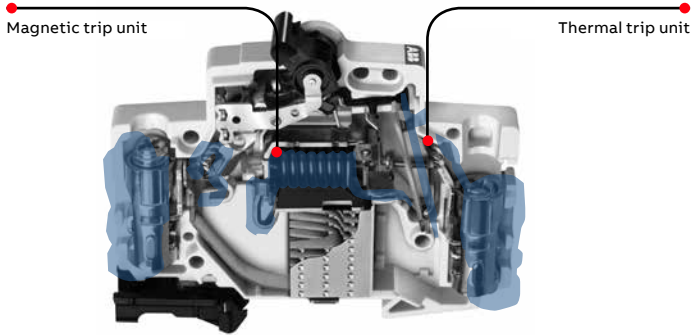

All highlighted components are energized during operation

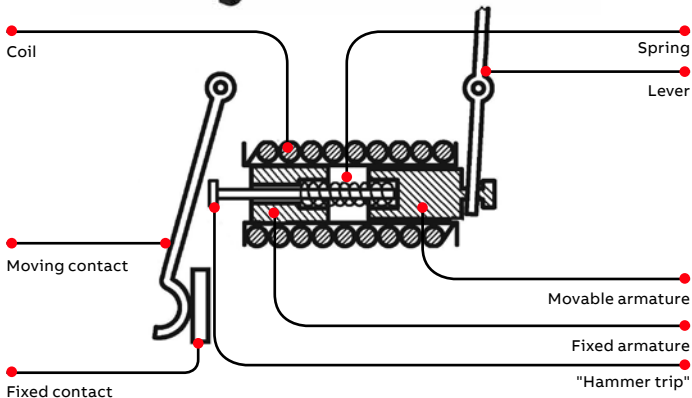
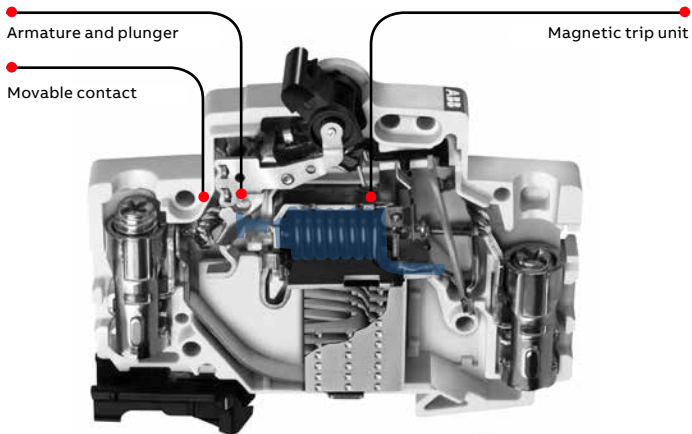
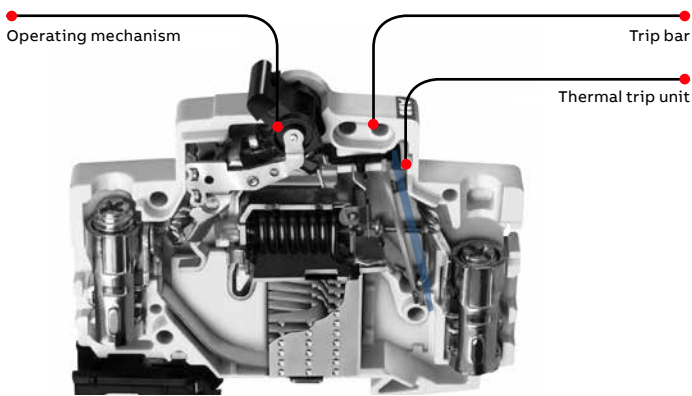

Thermal/magnetic trip units definition

ABB current-limiting breakers use an electromechanical (thermal/magnetic) trip unit to open the breaker contacts during an over-current event. The thermal trip unit is temperature sensitive and the magnetic trip unit is current sensitive. Both units act independently and mechanically with the breaker's trip mechanism to open the breaker's contacts.

Current flow during operation

Overload protection

The thermal trip unit protects against a continuous overload. The thermal unit is comprised of a bimetal element located behind the circuit breaker trip bar and is part of the breaker's current carrying path. When there is an overload, the increased current flow heats the bimetal, causing it to bend. As the bimetal bends, it pulls the trip bar that opens the breaker's contacts.

The time required for the bimetal to bend and trip the breaker varies inversely with the current. Because of this, the tripping time becomes quicker as current increases in magnitude.

Overload protection is applicable to any installation, conductor or component that can be subjected to low-magnitude but long-time over-currents. Low-magnitude, long-time over-currents can be dangerous because they reduce the life of the electrical installation, conductor and components. If left unchecked, fire could result.

Magnetic trip units (short circuit protection)

The magnetic trip unit protects against a short circuit. The magnetic trip unit is comprised of an electromagnet and an armature.

Components of a magnetic trip unit

When there is a short circuit, a high magnitude of current passes through the coils, creating a magnetic field that attracts the movable armature towards the fixed armature. The hammer trip is pushed against the movable contact and the contacts are opened. The opening of the breaker's contacts during a short circuit is complete in 0.5 milliseconds.

Circuit breaker construction

Arc runners/arc chutes

The arc runner guides the electric arc away from the open contacts into the arc chute, where it is extinguished.

During an overload or short circuit event, the contacts of the breaker separate, and an electrical arc is formed between the contacts through air. The arc is moved into the arc chute by “running” the arc down the interior of the breaker along the arc runner. When the arc reaches the arc chute, it is broken into small segmented arcs. The segmented arcs split the overall energy level into segments less than 25 V. Each 25 V segment does not have a high enough energy level to maintain an arc and all energy is naturally dissipated.

Breaker curves

Thermal trip unit (region one)

The first sloping region of the breaker curve is a graphical representation of the tripping characteristics of the thermal trip unit. This portion of the curve is sloped due to the nature of the thermal trip unit. The trip unit bends to trip the breaker’s trip bar in conjunction with a rise in amperage (temperature) over time. As the current on the circuit increases, the temperature rises, and the faster the thermal element will trip.

Example using the curve below: If you had a 10 amp breaker and the circuit was producing 30 amps of current, the breaker would trip between two seconds and one minute. In this

example, you would find the circuit current on the bottom of the graph (multiples of rated current). The first line is 10 amps (10 amp breaker x a multiple of one), the second line is 20 amps (10 amp breaker x multiple of two), and the third line is 30 amps (10 amp breaker x multiple of three). Next, you would trace the vertical 30 A line up until it intersects the red portion of the breaker thermal curve. If you follow the horizontal lines on both sides of the red curve to the left, you will see that the breaker can trip as fast as two seconds and no slower than one minute.

Magnetic trip unit (region two)

This region of the breaker curve is the instantaneous trip unit. ABB’s miniature circuit breaker’s instantaneous trip unit interrupts a short circuit in 2.3 to 2.5 milliseconds. Because of this, the curve has no slope and is graphically represented as a vertical straight line.

See curve example. If you had a 10 amp breaker, the magnetic trip element would interrupt a short circuit between 10 and 30 amps (10 amp breaker x multiple of two and three) in 2.3 to 2.5 milliseconds.

Breaker contacts (region three)

This region of the curve is the time required for the contacts of the breaker to begin to separate. The contacts will open in less than 0.5 milliseconds and is graphically represented by the bottom vertical portion of the curve.

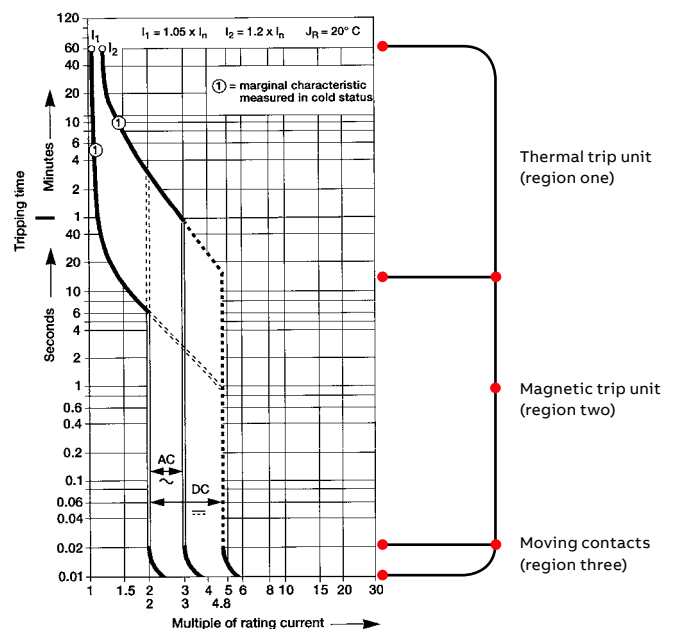
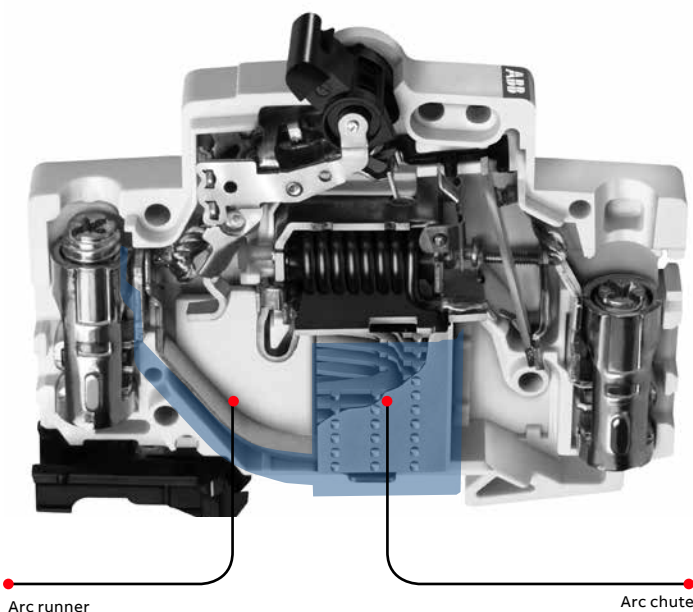

Circuit breaker current limitation

01 Current limiting
02 Zero point extinguishing

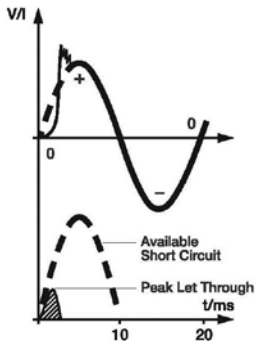

01

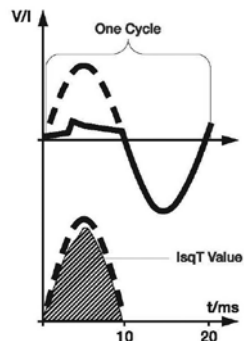

02

Current-limiting definitions

All ABB miniature circuit breakers are UL tested and certified as current-limiting protective devices. Current-limiting circuit breakers provide a higher level of circuit protection than typical zero point external breakers.

UL AC 60 Hz cycle

UL defines an AC cycle as the potential energy of the wave form traveling from zero-to-positive amplitude, positive-to-zero amplitude, zero-to-negative amplitude, negative-to-zero amplitude 60 times in one second. One cycle is completed every 16.6 milliseconds.

UL breaker current limiting

UL defines breaker current limitation as a breaker that interrupts and isolates a fault in less than $\frac{1}{2}$ of an AC cycle. $\frac{1}{2}$ a cycle is completed in 8.3 milliseconds.

NEC 240.2 current-limiting

A device that, when interrupting current in its current-limiting range, reduces the current flowing in the faulted circuit to a magnitude substantially less than that obtainable in the same circuit if the device were replaced with a solid conductor having comparable impedance.

IEC 60947-2 current-limiting circuit breaker

A circuit breaker with sufficiently short trip time to prevent the short-circuit current from reaching the peak value which would otherwise be reached.

ABB current-limiting breakers

ABB current-limiting breakers can interrupt and isolate a fault in $\frac{1}{4}$ of an AC cycle. The breaker fault interruption is completed in 2.3 to 2.5 milliseconds.

Zero point extinguishing breakers

A typical zero point extinguishing breaker interrupts a fault and does not isolate the energy. The breaker allows an arc to be present between the open contacts until the AC wave form crosses zero. When the wave form crosses zero, the potential energy is zero and the arc (fault) naturally extinguishes. The arc could be present for up to 8.3 milliseconds.

Current-limiting breakers and electrical networks

Current limitation

When a short-circuit condition occurs, the “ideal” current-limiting circuit breaker opens before the current waveform can reach its full potential magnitude, which occurs at $\frac{1}{4}$ cycle (4.17 ms). ABB’s current-limiting breakers can interrupt a fault in about $\frac{1}{2}$ cycle or 2.3 ms to 2.5 ms. ABB’s current-limiting breakers interrupt a short circuit in less than $\frac{1}{6}$ cycle and limit the amount of current that can reach a circuit. Limiting the available current on the circuit provides additional protection against network, breaker or bus damage and prevents the tripping of upstream breakers (selective coordination).

I^2t

The true destructive nature of a short circuit is measured by the time it is available combined with the peak value of the short circuit. The I^2t (amps squared over time) value represents the amount of energy available on a network during a short circuit and is represented by the shaded area on the graphs at left.

During a short circuit, both magnetic forces and thermal energy combine to damage devices on the electrical network. The level of thermal energy and magnetic forces are directly proportional to the square of the current. The magnetic forces vary as a square of the peak current available and the thermal energy varies as a square of the RMS (root mean square) current available.

ABB’s current-limiting breakers will limit the let-through energy to a fraction ($\frac{1}{100}$) of the value that is available from the network. By comparison, a zero crossing breaker would let through approximately 100 times as much destructive energy as the current-limiting circuit breaker [(100,000 A / 10,000 A) squared – 100X]. ABB’s current-limiting breakers limit the short circuit current to a relatively small magnitude in an extremely short time, which dramatically limits a short circuit’s destructive energy.

Circuit breaker current limitation

Current-limiting and zero crossing breakers

During the initial stages of a short circuit, a breaker’s contacts open to interrupt the circuit. After the contacts open, an arc forms in the air between the contacts on both the current-limiting and zero crossing breaker contacts. What distinguishes a current-limiting breaker from a zero crossing breaker is what each breaker does after an arc is formed between the open contacts.

A current-limiting breaker “runs” the arc down the breaker arc runner into an arc chute that extinguishes the arc.

A zero crossing breaker does not attempt to extinguish the arc. The breaker is designed to withstand the energy of the arc long enough for the waveform to cross zero. When the wave form crosses zero, the potential energy is zero and the arc naturally extinguishes itself.

ABB’s current-limiting breakers interrupt the arc energy in 2.3 ms to 2.5 ms ($\frac{1}{6}$ cycle), and a zero crossing breaker allows the arc to be present for up to 8.3 ms ($\frac{1}{2}$ cycle). A zero crossing breaker will let through 100 times as much energy as an ABB current-limiting breaker.

Current limiting example

The lab test report below details a 20 A S200 series current-limiting breaker interrupting a 28 kA fault in 1.7 milliseconds. The total “I Square T” value is 32.0 kA.

Zero crossing example

The test report below details a 20 A zero point extinguishing breaker interrupting a 9 kA fault in 9 milliseconds. The total “I Square T” value is 104.0 kA.

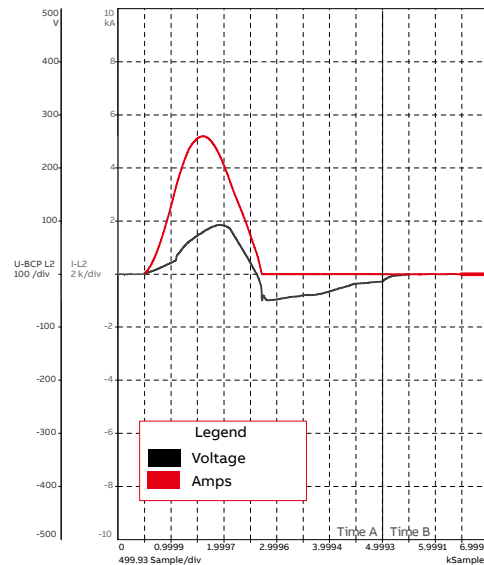
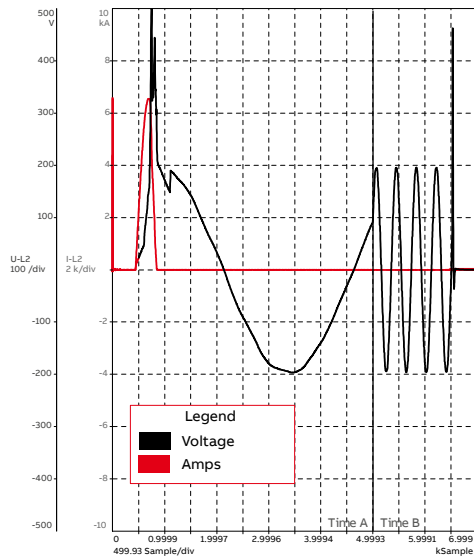
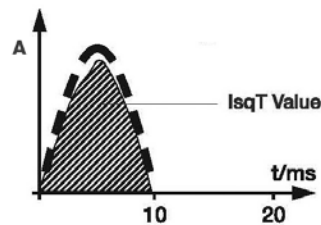
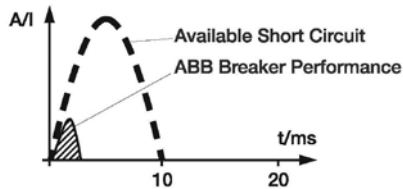

Selective coordination and series ratings

Definition of selective coordination

Coordination between the operating characteristics of two or more over-current protection devices, so that when an over-current within established limits occurs, the device designated to operate within those limits trips, whereas the other devices does not trip.

Example of breaker coordination

When an over-current event occurs at the branch breaker level (CB1), and the event is within the operating characteristics of the breaker, then the branch breaker should interrupt the circuit (open) and the main breaker should remain closed and energized. The chart below gives a graphical representation of a downstream branch breaker (B curve) and a main breaker (A curve) with coordination. The separation between the curves allows the branch breaker to react to the fault while the main breaker remains closed and energized.

Example of no breaker coordination

Selective breaker coordination is not achieved when there is an overload event at the branch breaker level (MCB1) and both the branch breaker and main breaker interrupt the circuit (open). When there is no breaker coordination, several circuits lose power that should remain operational during and after the overload event. The chart below gives a graphical representation of a downstream branch breaker (B curve) and a main breaker (A curve) without coordination. There is no separation between the curves. The branch breaker will react to a fault and the main breaker will open and de-energize all circuits down stream. Problems in coordination occur when the branch breaker allows the “I Square T” value of the short circuit to rise to a level that is in the operating range of the upstream main breaker. Proper breaker coordination is easier to achieve with the use of current-limiting breakers at the branch level.

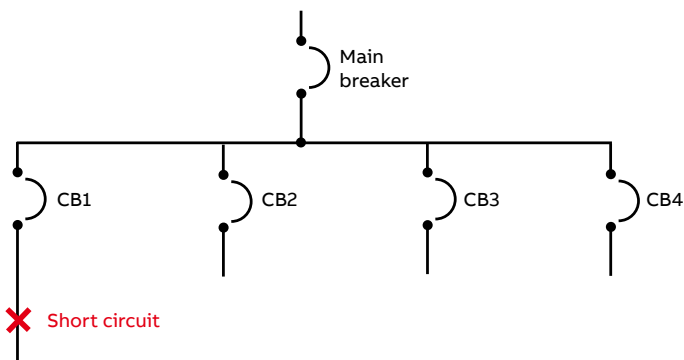

Selective coordination and current-limiting breakers

Recent improvements in ABB circuit breaker technology has pushed the performance of breakers to the same level as fuses. The reaction time and tripping characteristics of current-limiting breakers are now on par with fuses. This allows ABB to provide a high level of coordination between branch breakers and the main. A current-limiting branch breaker will limit the “I Square T” value well below the level of the operating range of the upstream main breaker. ABB’s current-limiting branch breakers can coordinate between the main breaker up to 35 kA.

Selective coordination and zero crossing breakers

Zero crossing breakers do not limit the “I Square T” value. They wait for the wave form to cross zero and allow a high level of let-through energy to pass through the system. The “I Square T” value of a zero crossing breaker is high enough that the main breaker will likely trip during a short circuit. With zero crossing breakers, it is extremely difficult to coordinate between branch and main breakers. A typical zero crossing breaker’s coordination level is below 10 kA. There are a few manufacturers that have achieved coordination between a branch zero crossing breaker and the main by slowing the performance (protection) of the main breaker.

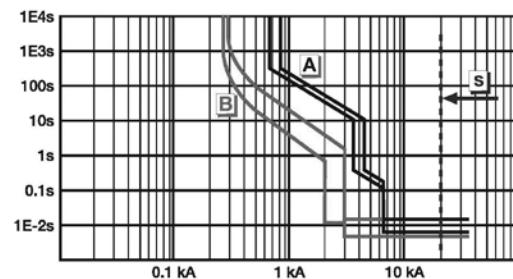

Coordination

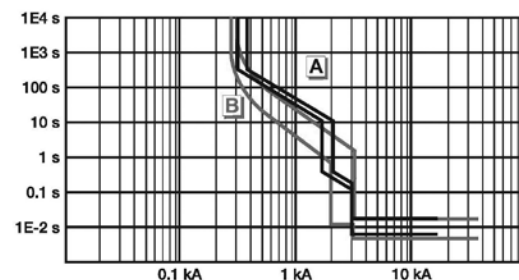

No coordination

Selective coordination and series ratings

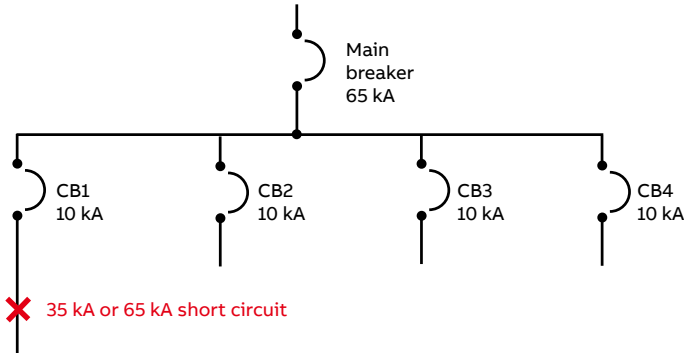

Selective coordination

Selective coordination is achieved when there is a short circuit on a branch circuit breaker, the branch breaker opens and isolates the fault, and the main breaker remains closed. The rating is usually a value above the “stand alone” interrupting rating of the branch breaker and the “stand alone” rating of the main breaker.

Example:

65 kA rated main breaker

10 kA rated branch breaker

Coordination between the two breakers up to 35 kA

There can be a short circuit on the branch breaker up to 35 kA where the branch will open (CB1) and the main breaker will remain closed. Although the branch has a 10 kA “stand alone” rating, both the breakers work together to limit the available short circuit to allow the branch (CB1) to isolate the fault.

Series ratings

Series ratings are different from coordination ratings. Unlike coordination ratings where the branch opens and the main remains closed, a series-rated combination is one where both the branch and main breakers open and work together to isolate the fault.

The series-rating combination of two breakers is equal to the “stand alone” interrupting value of the main breaker. This is a result of the main breaker let-through value being lower than the “stand alone” interrupting value of the branch breaker. During a short circuit, the main breaker will limit the energy to a level that is below the “stand alone” value of the branch breaker.

Example:

65 kA rated main breaker

10 kA rated branch breaker

Series-combination rating between the two breakers up to 65 kA

There can be a short circuit on the branch breaker up to 65 kA where the branch will open and the main breaker will open. Although the branch breaker (CB1) has a 10 kA “stand alone” rating, the main breaker has a let-through value below 10 kA. If there is a fault up to 65 kA on the network, the main breaker will limit the energy to a value less than the rating of the branch breaker (CB1). Both breakers will trip (no coordination), but the network can safely withstand a fault of 65 kA.

Miniature circuit breaker cutaway

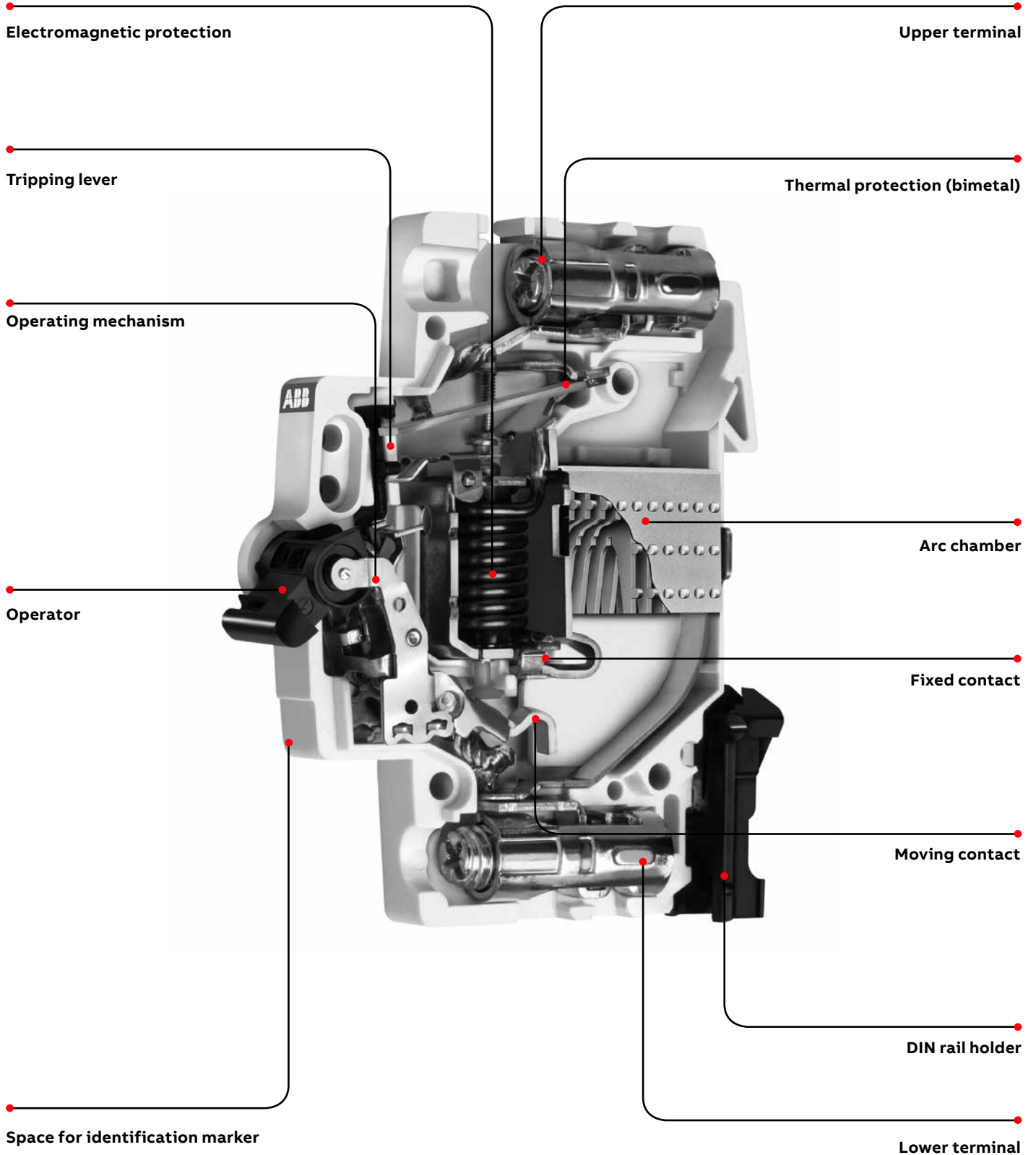

S800U series

High performance circuit breakers — UL 489 series



Description

The S800U high performance MCB offers a compact solution to circuit protection. The S800U devices are DIN rail mounted. The S800U is available with application-specific trip characteristics to provide maximum circuit protection.

The breakers offer thermal-magnetic trip protection according to Z and K characteristics.

For the worldwide market, the breakers carry CSA, IEC, CE and many other agency approvals.



Features

- Energy limiting
- Fast breaking time (2.3–2.5 ms)
- Wide range of accessories
- DIN rail mounting
- Finger-safe terminals
- Multi-function terminals
- Ring tongue compatible
- UL 489 File #E312425

	S800U	S800U-UCZ	S800U-PVS
Amperage	10–100 A	10–80 A	5 A
Voltage	240 V AC	600 V DC	1000 V DC
Poles	1, 2, 3, 4	4 in series	4 in series
Trip curves	Z, K	Z	PVS
Short circuit interrupt rating	30/50 kA (single-/multi-pole)	10 kA	3 kA
Auxiliary contacts	Yes	—	—
Bell alarm	Yes	—	—
Shunt trip	Yes	—	—
Undervoltage release	Yes	—	—
Terminals	Compression/ring tongue	Compression	Compression

S800U-K, 240 V AC

Branch circuit protection — UL 489

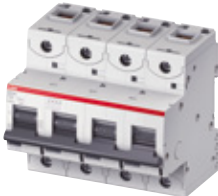

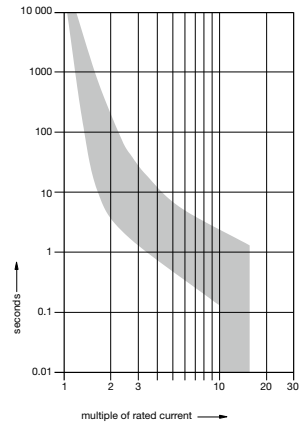

	Number of poles	Rated current		Number of poles	Rated current	
		I_n A	Cat. no.		I_n A	Cat. no.
	1	10	S801U-K10	3	10	S803U-K10
		15	S801U-K15		15	S803U-K15
		20	S801U-K20		20	S803U-K20
		25	S801U-K25		25	S803U-K25
		30	S801U-K30		30	S803U-K30
		40	S801U-K40		40	S803U-K40
		50	S801U-K50		50	S803U-K50
		60	S801U-K60		60	S803U-K60
		70	S801U-K70		70	S803U-K70
		80	S801U-K80		80	S803U-K80
	2	10	S802U-K10	4	10	S804U-K10
		15	S802U-K15		15	S804U-K15
		20	S802U-K20		20	S804U-K20
		25	S802U-K25		25	S804U-K25
		30	S802U-K30		30	S804U-K30
		40	S802U-K40		40	S804U-K40
		50	S802U-K50		50	S804U-K50
		60	S802U-K60		60	S804U-K60
		70	S802U-K70		70	S804U-K70
		80	S802U-K80		80	S804U-K80
	3	10	S803U-K10	4	10	S804U-K10
		15	S803U-K15		15	S804U-K15
		20	S803U-K20		20	S804U-K20
		25	S803U-K25		25	S804U-K25
		30	S803U-K30		30	S804U-K30
		40	S803U-K40		40	S804U-K40
		50	S803U-K50		50	S804U-K50
		60	S803U-K60		60	S804U-K60
		70	S803U-K70		70	S804U-K70
		80	S803U-K80		80	S804U-K80
	4	10	S804U-K10	4	10	S804U-K10
		15	S804U-K15		15	S804U-K15
		20	S804U-K20		20	S804U-K20
		25	S804U-K25		25	S804U-K25
		30	S804U-K30		30	S804U-K30
		40	S804U-K40		40	S804U-K40
		50	S804U-K50		50	S804U-K50
		60	S804U-K60		60	S804U-K60
		70	S804U-K70		70	S804U-K70
		80	S804U-K80		80	S804U-K80

Diagram



S800U-Z, 240 V AC

Branch circuit protection — UL 489

	Number of poles	Rated current		Number of poles	Rated current	
		I_n A	Cat. no.		I_n A	Cat. no.
	1	10	S801U-Z10	3	10	S803U-Z10
		15	S801U-Z15		15	S803U-Z15
		20	S801U-Z20		20	S803U-Z20
		25	S801U-Z25		25	S803U-Z25
		30	S801U-Z30		30	S803U-Z30
		40	S801U-Z40		40	S803U-Z40
		50	S801U-Z50		50	S803U-Z50
		60	S801U-Z60		60	S803U-Z60
		70	S801U-Z70		70	S803U-Z70
		80	S801U-Z80		80	S803U-Z80
	2	10	S802U-Z10	4	10	S804U-Z10
		15	S802U-Z15		15	S804U-Z15
		20	S802U-Z20		20	S804U-Z20
		25	S802U-Z25		25	S804U-Z25
		30	S802U-Z30		30	S804U-Z30
		40	S802U-Z40		40	S804U-Z40
		50	S802U-Z50		50	S804U-Z50
		60	S802U-Z60		60	S804U-Z60
		70	S802U-Z70		70	S804U-Z70
		80	S802U-Z80		80	S804U-Z80
	3	10	S803U-Z10	4	10	S804U-Z10
		15	S803U-Z15		15	S804U-Z15
		20	S803U-Z20		20	S804U-Z20
		25	S803U-Z25		25	S804U-Z25
		30	S803U-Z30		30	S804U-Z30
		40	S803U-Z40		40	S804U-Z40
		50	S803U-Z50		50	S804U-Z50
		60	S803U-Z60		60	S804U-Z60
		70	S803U-Z70		70	S804U-Z70
		80	S803U-Z80		80	S804U-Z80
	4	10	S804U-Z10	4	10	S804U-Z10
		15	S804U-Z15		15	S804U-Z15
		20	S804U-Z20		20	S804U-Z20
		25	S804U-Z25		25	S804U-Z25
		30	S804U-Z30		30	S804U-Z30
		40	S804U-Z40		40	S804U-Z40
		50	S804U-Z50		50	S804U-Z50
		60	S804U-Z60		60	S804U-Z60
		70	S804U-Z70		70	S804U-Z70
		80	S804U-Z80		80	S804U-Z80
90	S804U-Z90	90	S804U-Z90			
		100	S804U-Z100	100	S804U-Z100	

Diagram

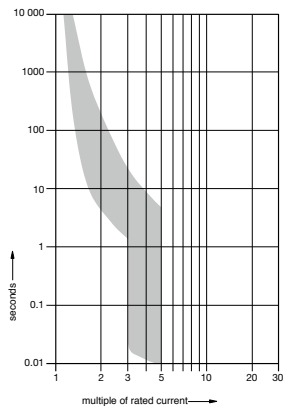

S804U-PVS5

The S804U-PVS5 is for GFDI (ground-fault detector interrupter) applications in photovoltaic systems. In case of a ground fault, the breaker will trip and the PV generator will not be damaged. The breaker is tested according to UL 489B for 1000V DC.

Technical specifications

Standard	UL 489B
Characteristic	PV-S
Rated current I_n	5 A
Rated voltage U_n	1000V DC
No. of poles	4
Short-circuit current rating acc. to UL 489B	3 kA
Connections 5 A	
Single conductor per terminal—copper only, 75C wire	14–2 AWG Cu, solid or stranded
Tightening torque	3.5 Nm (31 in.lb.)
Protection category	IP40 (actuating end only)
Mounting position	Any
Contacts	Cadmium-free
Reference temperature for tripping characteristic	50 °C
Ambient temperature	-25 °C to 60 °C
Storage temperature	-40 °C to 70 °C
Approval	cULus File #E351317

Ordering information



Rated current (A)

5

Cat. no.

S804U-PVS5

S804U-PVS5

Tested and listed wirings

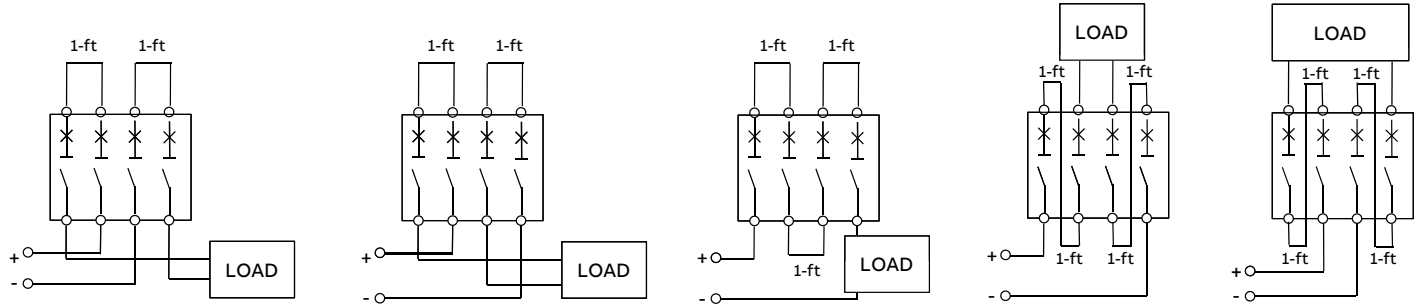

Trip curve for S804U-PVS5

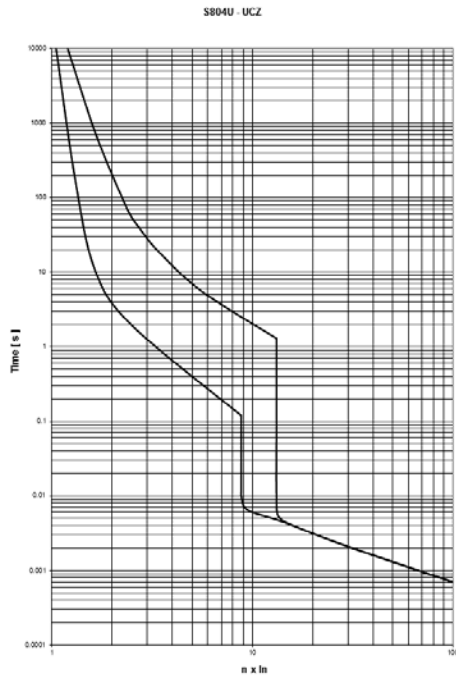

Dimension S804U-PVS5

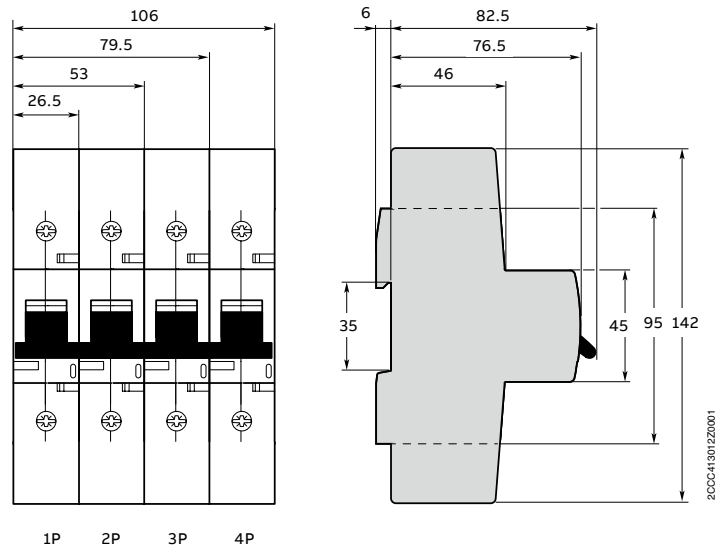

All dimensions shown are in mm.

Tripping behavior acc. to UL 489

Thermal release: 1.13–1.30 x In

Magnetic release: 6 x In

S804U-UCZ

This breaker is specially designed for networks up to 600 V DC, i.e., a data center. It is available as 4-pole version with a short-circuit current rating of 10 kA according to UL 489.

Technical specifications

Standard	UL 489
Characteristic	Z
Rated current I_e	10–80 A
Rated voltage U_e	600 V DC
No. of poles	4
Short-circuit current rating acc. to UL 489	10 kA
Tightening torque	3.5 Nm (31 in.lb.)
Protection category	IP40 (actuating end only)
Mounting position	Any
Contacts	Cadmium-free
Reference temperature for tripping characteristic	25 °C
Ambient temperature	-25 °C to 60 °C
Storage temperature	-40 °C to 70 °C
Approval	cULus File #E312425

Ordering information



Rated current (A)	Cat. no.
10	S804U-UCZ10
15	S804U-UCZ15
20	S804U-UCZ20
25	S804U-UCZ25
30	S804U-UCZ30
40	S804U-UCZ40
50	S804U-UCZ50
60	S804U-UCZ60
70	S804U-UCZ70
80	S804U-UCZ80

S804U-UCZ

Tested and listed wirings

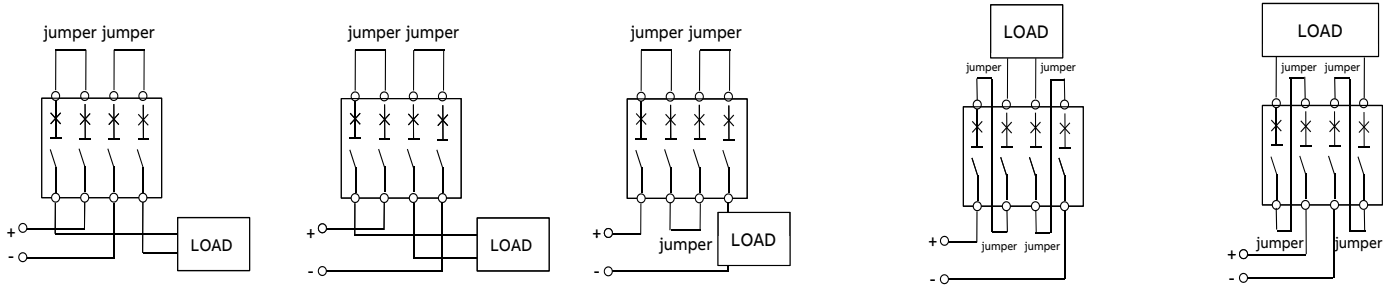

Line and load might be reversed

Ampere rating	10–32 A	40–63 A	70–80 A
Conductor type	Single conductor per terminal – copper only, 60/75 °C wire	Single conductor per terminal – copper only, 60 °C wire only	Single conductor per terminal – copper only, 60 °C wire only
AWG, wire range	14 AWG–2 AWG Cu, solid or stranded	1/0 AWG–8 AWG Cu, solid or stranded	1/0 AWG–8 AWG Cu, solid or stranded
Jumper length	1 ft. 30.5 cm	1 ft. 30.5 cm	2 ft. 61 cm

Trip curves for S804U-UCZ

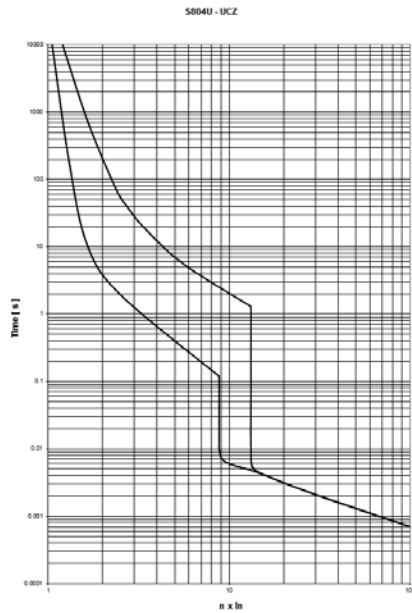

Dimension of S804U-UCZ

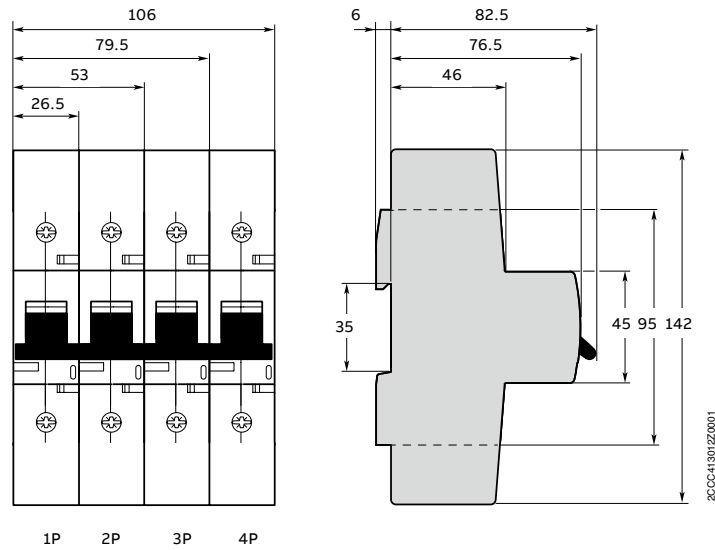

All dimensions shown are in mm.

Tripping behavior acc. to UL489

Thermal tripping: 1.00...1.35 x Ie

Electromagnetic tripping 11 x Ie ± 20 %

S803W-SCL-SR UL Short circuit current limiter, self-resetting

UL version short circuit current limiter, self-resetting, 3 pole



Description	Cat. no.
32 A Self-resetting current limiter	S803W-SCL32-SR
63 A Self-resetting current limiter	S803W-SCL63-SR
100 A Self-resetting current limiter	S803W-SCL100-SR

Technical specifications

Rated voltage	600 V AC per UL508
Short circuit current rating according to UL508, CSA 22.2	480 V AC 50/60 Hz, 65 kA 600 V AC 50/60 Hz, 65 kA

Approved combinations with motor starter

Downstream devices				Upstream devices			
Rated current				Rated current			
I_e [A]				I_e [A]			
MS/MO325				MS/MO132			
0.1-2.5	•	•	•	0.1-2.5	•	•	•
4	•	•	•	4	•	•	•
6.3	•	•	•	6.3	•	•	•
9	•	•	•	10	•	•	•
12.5	•	•	•	16	•	•	•
16	•	•	•	20	•	•	•
20	•	•	•	25	•	•	•
25	•	•	•	32	•	•	•

-Combinations with S500-K and S500-KM on request.

•Applies for all voltages according to the table below

Rated ultimate short-circuit breaking capacity

Short-circuit rating according to UL 508, CSA 22.2	kA
(AC) 50/60 Hz 480 V	65
(AC) 50/60 Hz 600 V	65
$I_{cu} = I_{cs}$ according to IEC 60947-2	
(AC) 50/60 Hz 240/415 V	100
(AC) 50/60 Hz 254/440 V	100
(AC) 50/60 Hz 277/480 V	65
(AC) 50/60 Hz 289/500 V	65
(AC) 50/60 Hz 346/600 V	65
(AC) 50/60 Hz 400/690 V	50

Approximate dimensions

S803W-SCL-SR UL 508 Short circuit current limiter, self-resetting

Minimum cable length between S803W-SCL-SR and downstream devices
(Connection has to be short-circuit proofed acc. to IEC 61439-1)

MS/M0325
MS/M0132
S800

S800-SCL-SR	Min. length X (mm)	Min. cross section (mm ²)
32 A	80	6
63 A	80	16
100/125 A	250	35

Diagrams

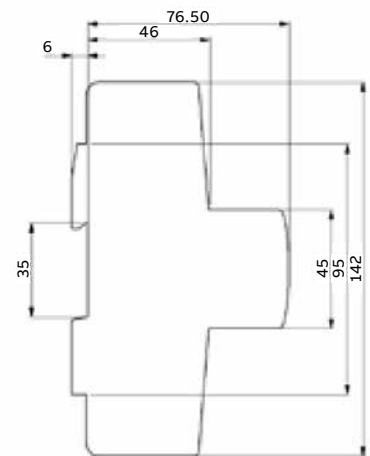
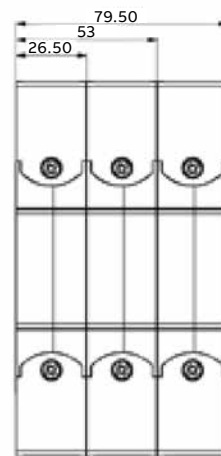
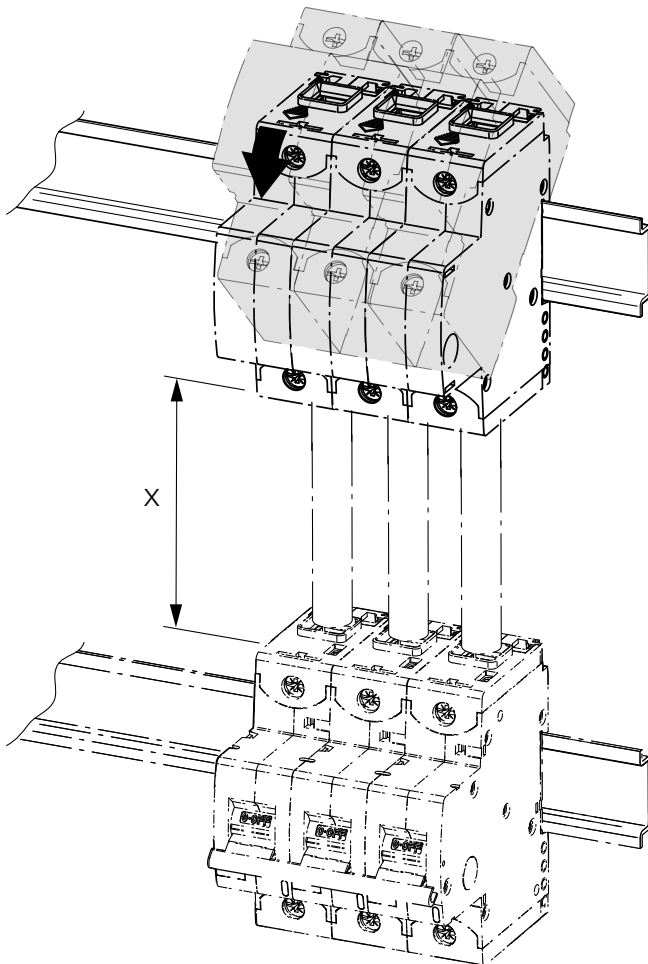

All dimensions shown are in mm.

S800W-RSU Remote switching unit

UL 489

Remote switching unit

	Description	Cat. no.
S800W-RSU (breaker is not included)	Remote switching unit	S800W-RSU



Key features

- The remote switching unit S800W-RSU has a brushless high precision DC motor to ensure fast remote control operation
- Low power consumption
- Short switching times
- The S800W-RSU is mounted on any multi-pole S800 high-performance MCB
- Installation and wiring can be field installable
- The connection is done by a 10-pole Micro-Fit 3.0™ (not included in delivery)
- The S800W-RSU can be operated by a standard pushbutton or drive by a PLC

Switching times

- OFF -> ON <<500 ms
from signal to contact closing
- ON -> OFF <<250 ms
from signal to contact opening
- TRIP -> OFF -> ON <<1500 ms
from signal to contact closing

Safety intelligence

- Inputs are deactivated when detecting manual use
- All outputs become active when spindle is rotated more than 360°
- S800W-RSU is locked for five minutes after three switching attempts leading to a trip
- Manual switch off possible for three- and four-pole devices

S800-RSU cable including plug

	Description	Cat. no.
	3 meter cable 0.5 mm ² (20 AWG) including 10-pole Micro-Fit 3.0™ plug	S800-RSU-CP



Technical specifications

Operational voltage	24 V DC
Current consumption I_{ms}	2, 5
Standby current $I_{standby}$	< 50 mA
Switching time OFF-ON	< 500 msec
Switching time ON-OFF	< 250 msec
Ambient operation temperature	-25 °C to 70 °C
Number of switching operations	10.000
Maximum cable lengths (20 AWG/0.5 mm ²)	10 m
Degree of protection (mounted)	IP2
Weight	0.661387 lb.
Connection	10-pole Micro-Fit 3.0™

Diagrams

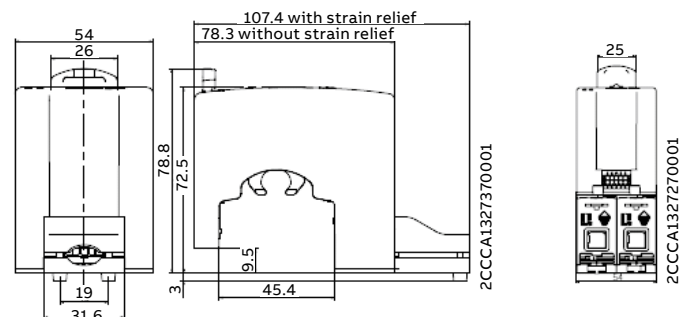

Approximate dimensions shown are in mm.

Accessories

S800U

Shunt trip

For remote tripping of breaker, a shunt trip device can be added to the MCB. The device opens the breaker after control voltage is applied.

	Description (for field mounting, left side)	Cat. no.
	S800-SOR Shunt operation release 24 V AC/DC	S800-SOR24
	Shunt operation release 48–130 V AC/DC	S800-SOR130
	Shunt operation release 110–250 V AC/DC	S800-SOR250

Under-voltage release

When control voltage drops below approximately 50 percent of rated voltage, the UVR opens the breaker. The breaker cannot be operated unless proper control voltage is first applied to the UVR coil.

	Description	Cat. no.
	S800-UVR Under-voltage release 24–36 V AC/DC	S800-UVR36
	Under-voltage release 48–60 V AC/DC	S800-UVR60
	Under-voltage release 110–130 V AC/DC	S800-UVR130
	Under-voltage release 220–250 V AC/DC	S800-UVR250

Auxiliary contacts

The auxiliary contacts will signal whether the breaker is in the ON or OFF position.

	Description	Cat. no.
	Auxiliary contact	S800-AUX

Bell alarm

The bell alarm includes a set of contacts that will only signal when the breaker has tripped. Typically, the contacts would be connected to an alarm or bell to signal the operator that an overcurrent trip has occurred. The bell alarm also includes a test button for testing the alarm contacts without opening the breaker.

	Cat. no.
	S800-AUX/ALT

Ring tongue adapter

	Cat. no.
	S800-RT2125

Accessories

S800U

Rotary operating mechanism

Allows “through-the-door” operation.

	Description	Cat. no.
	Handle mechanism	S800-RD

	Description	Cat. no.
	Gray rotary handle	S800-RHE-H

UL locking device

	Description	Cat. no.
	Red rotary handle	S800-RHE-EM

	Description	Cat. no.
	Shaft extension	S800-RHE-S

	Description	Cat. no.
	Padlock not included	S800U-PLL

Technical specifications

S800U

					S800U
Characteristics					K, Z
Rated operational current I_e				[A]	10...100
Pole					1...4
Rated operational voltage U_e compliant to UL489					
(AC)		50/60 Hz		[V]	240
Rated ultimate short-circuit breaking capacity compliant to UL489					
(AC)	50/60 Hz	240 V	Single-pole	[kA]	30
(AC)	50/60 Hz	240 V	Multi-pole	[kA]	50
Rated operational voltage U_e compliant to IEC 60947-2					
(AC)				[V]	240/415
Rated ultimate short-circuit breaking capacity I_{cu} compliant to IEC 60947-2					
(AC)	50/60 Hz	240/415 V	Single-pole	[kA]	30
(AC)	50/60 Hz	240/415 V	Multi-pole	[kA]	50
Rated service short-circuit breaking capacity I_{cs} compliant to IEC 60947-2					
(AC)	50/60 Hz	240/415 V	Single-pole	[kA]	25
(AC)	50/60 Hz	240/415 V	Multi-pole	[kA]	40
Connections C_u					
				10–30 A	14–2 AWG
				40–100 A	8–1 AWG
Rated frequency				[Hz]	50/60
Tightening torque				[Nm]	3,5 (31 in. lb.)
Protection category					IP40 (actuating end only)
Mounting position					Any
Contacts					Cadmium-free
Permissible ambient temperature				[°C]	-25 °C to 60 °C
Standards					UL489 IEC 60947-2 CSA22.2 No.5-02
Approval					cULus File E312425

Technical specifications

S800U

Typical internal resistances and power losses at 25 °C ambient temperature

Rated current I_n [A]	Internal resistance R_i [mΩ] K, Z	Power loss P_v [W] K, Z
10	15.2	1.5
15	12.1	2.7
20	8.7	3.5
25	6.8	4.2
30	3.1	2.8
40	2.3	3.7
50	1.7	4.3
60	1.6	5.8
70	1.0	6.4
80	1.0	6.4
90	0.8	6.5
100	0.8	8.3

Influence of ambient temperature

Devices mounted singly (specifications in A).

S800U-K, -Z

I_n [A]	10 °C	15 °C	20 °C	25 °C	30 °C	35 °C	40 °C	45 °C	50 °C	55 °C	60 °C
10	10.9	10.7	10.4	10.0	9.6	9.3	9.0	8.7	8.4	8.0	7.6
15	16.5	16.0	15.6	15.0	14.4	14.0	13.5	13.0	12.6	12.0	11.4
20	22.0	21.4	20.8	20.0	19.2	18.6	18.0	17.4	16.8	16.0	15.2
25	27.5	26.8	26.0	25.0	24.0	23.3	22.5	21.8	21.0	20.0	19.0
30	33.1	32.1	31.2	30.0	28.8	27.9	27.0	26.1	25.2	24.0	22.9
40	44.0	42.8	41.6	40.0	38.4	37.2	36.0	34.8	33.6	32.0	30.9
50	55.1	53.5	52.0	50.0	48.0	46.5	45.0	43.5	42.0	40.0	38.3
60	66.2	64.2	62.4	60.0	57.6	55.8	54.0	52.2	50.4	48.0	46.0
70	76.9	74.9	72.8	70.0	67.2	65.1	63.0	60.9	58.8	56.0	53.4
80	88.0	85.6	83.2	80.0	76.8	74.4	72.0	69.6	67.1	64.0	61.6
90	99.1	96.3	93.6	90.0	86.4	83.7	81.0	78.3	75.6	72.0	69.5
100	110.5	107.0	104.0	100.0	96.0	93.0	90.0	87.0	83.8	80.0	77.8

Technical specifications

S800U

Auxiliary contact S800-AUX

	S800-AUX
Usage category	AC15 400/2 A-UL AC15 240/ -UL DC13 250/0.55 A125 V/1.1A-IEC DC13 125 V/1.1A DC13 60 V/2A DC13 24 V/4A
Continuous thermal current I_n	6 A
Rated insulation voltage U_i	690 V
Number of contacts	2
Surge U_{test} (1.2/50 μ s)	6 kV
Degree of protection	3
Function of contact	Changeover contacts
Connection Cu	1 x 2.5 mm ² 2 x 1.5 mm ²
Tightening torque	1 Nm
Ensured contacts during shake test	5g, 20 frequency cycle
acc. to IEC 68-2-6	at 24 V AC/DC, 5mA brief interrupt <10 ms
AC/DC supply	Any EN 60715
Mounting on DIN top hat rail	EN 60715 IP20
Type of protection	IP20
Permissible ambient temperature for operations	-25 °C to 60 °C; -13 °F to 140 °F
Storage temperature	-40°C to 70 °C; -40 °F to 158 °F
Mechanical device service life	6000 switching cycles
I_{cu} with S450E	1000 A
Resistance to vibration	IEC 60068-2-27; IEC 60068-2; EN 61373 Cat. 1/class B

Undervoltage release S800-UVR

	S800-UVR36	S800-UVR60	S800-UVR130	S800-UVR250
Rated voltage U_e	24–36 V AC/DC	48–60 V AC/DC	110–30 V AC/DC	220–250 V AC/DC
Operating range				
Operating opening				35...70% U_e
Operating closing				85% U_e
Rated insulation voltage U_i				690 V
Coil pull in consumption	1 W, 14 VA	1 W, 25 VA	1 W, 41 VA	1 W, 91 VA
Rated frequency				DC; 50/60 Hz
Protection degree				3
Connection Cu				1...35 cable
Tightening torque				min. 3/max. 4 Nm
AC/DC supply				Any
DIN top hat rail				EN 60715
Type of protection				IP20 IP40 (only actuation side)
Permissible ambient temperature of operations				-25 °C to 60 °C; -13 °F to 140 °F
Storage temperature				-40°C to 70 °C; -40 °F to 158 °F
S800-UVR36			IEC 60068-2-27; IEC 60068-2; EN61373 Cat. 1/class B	

Technical specifications

S800U

Combined auxiliary and bell alarm

Usage category	AC15 400/2 A-UL AC15 240/6A-UL DC13 250/0.55 A125 V/1.1A-IEC DC13 125 V/1.1A-IEC DC13 60 V/2A DC13 24 V/4A
Continuous thermal current I_n	6 A
Rated insulation voltage U_i	690 V
Number of contacts	2 (1x AUX, 1 x AUX/ALT)
Surge U_{test} (1.2/50 μ s)	6 kV
Degree of protection	3
Function of contact	Changeover contacts
Connection Cu	1 x 2.5 mm ² 2 x 1.5 mm ²
Tightening torque	1 Nm
Ensured contacts during shake test	5g, 20 frequency cycle
acc. to IEC 68-2-6	5...150...5 Hz at 24 V AC/DC, 5 mA brief interrupt <10 ms
AC/DC supply	Any EN 60715
Mounting on DIN top hat rail	EN 60715
Type of protection	IP20
Permissible ambient temperature for operations	-25 °C to 60 °C; -13 °F to 140 °F
Storage temperature	-40°C to 70 °C; -40 °F to 158 °F
Mechanical device service life	6000 switching cycles
I_{cu} with S450E	1000 A
Resistance to vibration	IEC 60068-2-27; IEC 60068-2; EN 61373 Cat. 1/class B

Shunt operation release — S800-SOR

	S800-SOR24	S800-SOR130	S800-SOR250	S800-SOR400
Rated voltage U_e	24 V AC/DC	48–130 V AC/DC	110–250 V AC/DC	220–250 V AC/DC
Operating range				70–110% U_e
Rated insulation voltage U_i				690 V
Coil pull in consumption	19.2 W/VA			On request
Rated frequency				DC; 50/60 Hz
Protection degree				3
Connection Cu				1–35 AWG
Tightening torque				min. 3/max. 4 Nm
AC/DC supply				Any
DIN top hat rail				EN 60715
Type of protection				IP20 IP40 (only actuation side)
Permissible ambient temperature of operations				-25 °C to 60 °C; -13 °F to 140 °F
Storage temperature				-40°C to 70 °C; -40 °F to 158 °F
S800-UVR36				IEC 60068-2-27; IEC 60068-2; EN61373 Cat. 1/class B

Approximate dimensions

S800U

S800U

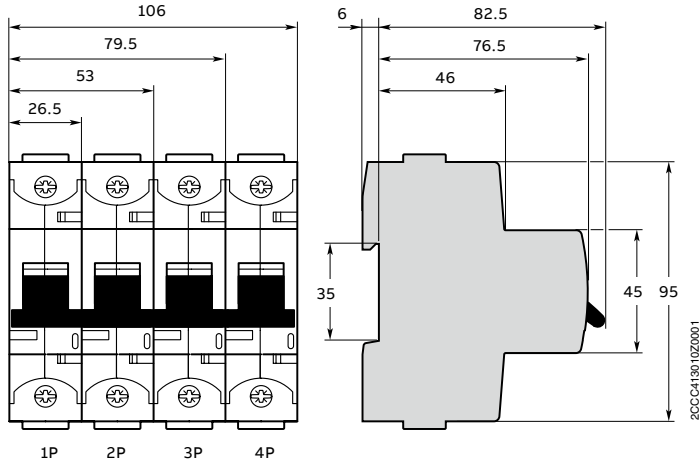

S800-SOR and S800-UVR

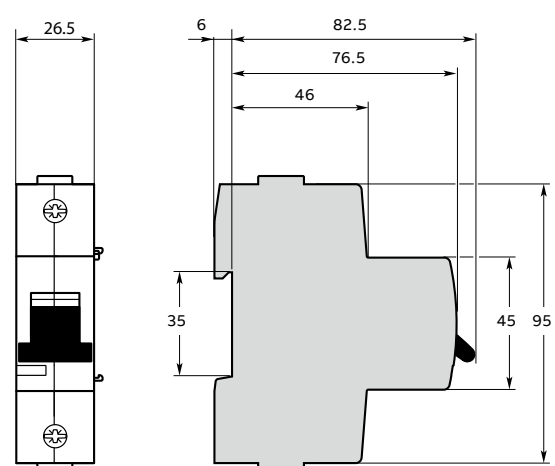

S800-AUX

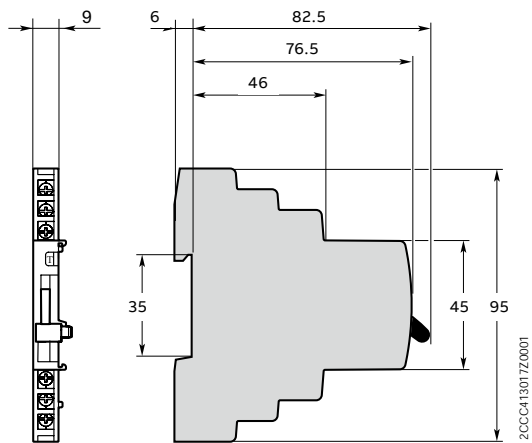

S800-AUX/ALT

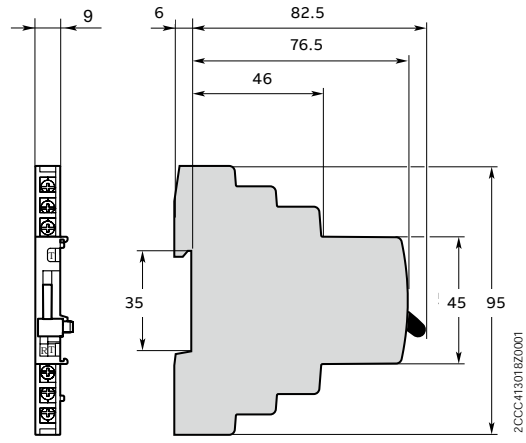

S800-RD AND S800-RHE

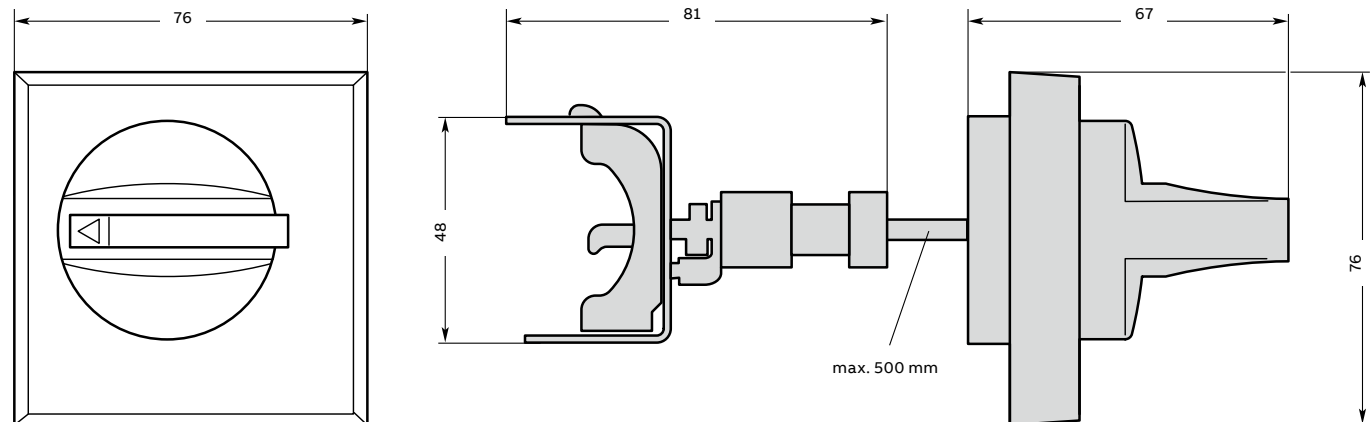

All dimensions shown are in mm.

S800C and S800S

High performance circuit breaker for IEC and UL 1077 applications

The high performance circuit breakers S800C and S800S are designed for use in IEC and UL applications and available in 1-, 2-, 3- and 4-pole versions.

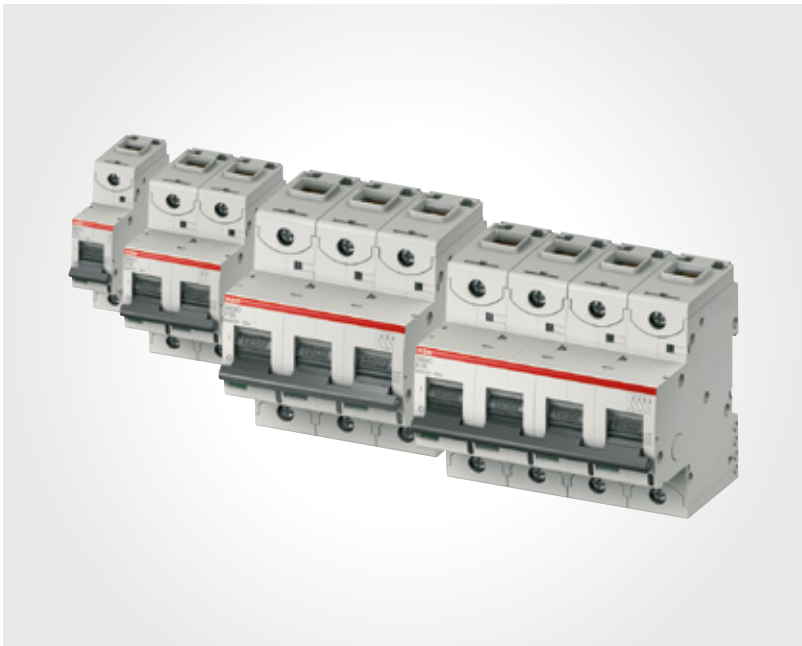

The small pole width of only 27 mm allows a space-saving installation. The current range covers nominal rated currents from 10 A up to 100 A (S800C) and 6 A up to 63 A (S800S) with a maximum rated short-circuit interrupt rating of up to 20 kA (S800C) and 30 kA (S800S) in UL applications.



Due to the number of global standards met by the S800C/S, the flexibility for worldwide installation is high. A single product can fulfill the needs of both, IEC and UL applications.

Features

- Rated operational voltage up to 480Y/277 V AC – 500 V DC (S800C) and 600Y/347 V AC (S800S), respectively (UL)
- Compression terminals can be easily converted to ring tongue terminals
- Compact
- Space saving



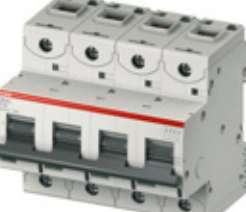

S800C-B

With interchangeable cage terminal

	Number of poles			Rated current [A]			Cat. no.						
	1	2	3	10	13	16	20	25	32	40	50	63	80
	1		3	10	S801C-B10	3	10	S803C-B10					
				13	S801C-B13		13	S803C-B13					
				16	S801C-B16		16	S803C-B16					
				20	S801C-B20		20	S803C-B20					
				25	S801C-B25		25	S803C-B25					
				32	S801C-B32		32	S803C-B32					
				40	S801C-B40		40	S803C-B40					
				50	S801C-B50		50	S803C-B50					
				63	S801C-B63		63	S803C-B63					
				80	S801C-B80		80	S803C-B80					
	2		4	10	S802C-B10	4	10	S804C-B10					
				13	S802C-B13		13	S804C-B13					
				16	S802C-B16		16	S804C-B16					
				20	S802C-B20		20	S804C-B20					
				25	S802C-B25		25	S804C-B25					
				32	S802C-B32		32	S804C-B32					
				40	S802C-B40		40	S804C-B40					
				50	S802C-B50		50	S804C-B50					
				63	S802C-B63		63	S804C-B63					
				80	S802C-B80		80	S804C-B80					
	3		4	10	S802C-B10	4	10	S804C-B10					
				13	S802C-B13		13	S804C-B13					
				16	S802C-B16		16	S804C-B16					
				20	S802C-B20		20	S804C-B20					
				25	S802C-B25		25	S804C-B25					
				32	S802C-B32		32	S804C-B32					
				40	S802C-B40		40	S804C-B40					
				50	S802C-B50		50	S804C-B50					
				63	S802C-B63		63	S804C-B63					
				80	S802C-B80		80	S804C-B80					
	4		4	10	S802C-B10	4	10	S804C-B10					
				13	S802C-B13		13	S804C-B13					
				16	S802C-B16		16	S804C-B16					
				20	S802C-B20		20	S804C-B20					
				25	S802C-B25		25	S804C-B25					
				32	S802C-B32		32	S804C-B32					
				40	S802C-B40		40	S804C-B40					
				50	S802C-B50		50	S804C-B50					
				63	S802C-B63		63	S804C-B63					
				80	S802C-B80		80	S804C-B80					
100	S802C-B100	100	S804C-B100										





S800C-C

With interchangeable cage terminal

	Number of poles	Rated current [A]	Cat. no.	Number of poles	Rated current [A]	Cat. no.
	1	10	S801C-C10	3	10	S803C-C10
		13	S801C-C13		13	S803C-C13
		16	S801C-C16		16	S803C-C16
		20	S801C-C20		20	S803C-C20
		25	S801C-C25		25	S803C-C25
		32	S801C-C32		32	S803C-C32
		40	S801C-C40		40	S803C-C40
		50	S801C-C50		50	S803C-C50
		63	S801C-C63		63	S803C-C63
		80	S801C-C80		80	S803C-C80
	2	10	S802C-C10	4	10	S804C-C10
		13	S802C-C13		13	S804C-C13
		16	S802C-C16		16	S804C-C16
		20	S802C-C20		20	S804C-C20
		25	S802C-C25		25	S804C-C25
		32	S802C-C32		32	S804C-C32
		40	S802C-C40		40	S804C-C40
		50	S802C-C50		50	S804C-C50
		63	S802C-C63		63	S804C-C63
		80	S802C-C80		80	S804C-C80
	3	10	S803C-C10	3	10	S803C-C10
		13	S803C-C13		13	S803C-C13
		16	S803C-C16		16	S803C-C16
		20	S803C-C20		20	S803C-C20
		25	S803C-C25		25	S803C-C25
		32	S803C-C32		32	S803C-C32
		40	S803C-C40		40	S803C-C40
		50	S803C-C50		50	S803C-C50
		63	S803C-C63		63	S803C-C63
		80	S803C-C80		80	S803C-C80
	4	10	S804C-C10	4	10	S804C-C10
		13	S804C-C13		13	S804C-C13
		16	S804C-C16		16	S804C-C16
		20	S804C-C20		20	S804C-C20
		25	S804C-C25		25	S804C-C25
		32	S804C-C32		32	S804C-C32
		40	S804C-C40		40	S804C-C40
		50	S804C-C50		50	S804C-C50
		63	S804C-C63		63	S804C-C63
		80	S804C-C80		80	S804C-C80
100	S804C-C100	100	S804C-C100			



S800C-D

With interchangeable cage terminal

	Number of poles	Rated current [A]	Cat. no.	Number of poles	Rated current [A]	Cat. no.
	1	10	S801C-D10	3	10	S803C-D10
		13	S801C-D13		13	S803C-D13
		16	S801C-D16		16	S803C-D16
		20	S801C-D20		20	S803C-D20
		25	S801C-D25		25	S803C-D25
		32	S801C-D32		32	S803C-D32
		40	S801C-D40		40	S803C-D40
		50	S801C-D50		50	S803C-D50
		63	S801C-D63		63	S803C-D63
		80	S801C-D80		80	S803C-D80
	2	10	S802C-D10	4	10	S804C-D10
		13	S802C-D13		13	S804C-D13
		16	S802C-D16		16	S804C-D16
		20	S802C-D20		20	S804C-D20
		25	S802C-D25		25	S804C-D25
		32	S802C-D32		32	S804C-D32
		40	S802C-D40		40	S804C-D40
		50	S802C-D50		50	S804C-D50
		63	S802C-D63		63	S804C-D63
		80	S802C-D80		80	S804C-D80
	3	10	S803C-D10	3	10	S803C-D10
		13	S803C-D13		13	S803C-D13
		16	S803C-D16		16	S803C-D16
		20	S803C-D20		20	S803C-D20
		25	S803C-D25		25	S803C-D25
		32	S803C-D32		32	S803C-D32
		40	S803C-D40		40	S803C-D40
		50	S803C-D50		50	S803C-D50
		63	S803C-D63		63	S803C-D63
		80	S803C-D80		80	S803C-D80
	4	10	S804C-D10	4	10	S804C-D10
		13	S804C-D13		13	S804C-D13
		16	S804C-D16		16	S804C-D16
		20	S804C-D20		20	S804C-D20
		25	S804C-D25		25	S804C-D25
		32	S804C-D32		32	S804C-D32
		40	S804C-D40		40	S804C-D40
		50	S804C-D50		50	S804C-D50
		63	S804C-D63		63	S804C-D63
		80	S804C-D80		80	S804C-D80
100	S804C-D100	100	S804C-D100			



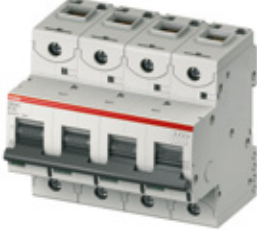

S800C-K

With interchangeable cage terminal

	Number of poles			Rated current [A]			Cat. no.							
	1	2	3	10	13	16	20	25	32	40	50	63	80	100
	1		3	10	S801C-K10	3	10	S803C-K10						
				13	S801C-K13		13	S803C-K13						
				16	S801C-K16		16	S803C-K16						
				20	S801C-K20		20	S803C-K20						
				25	S801C-K25		25	S803C-K25						
				32	S801C-K32		32	S803C-K32						
				40	S801C-K40		40	S803C-K40						
				50	S801C-K50		50	S803C-K50						
				63	S801C-K63		63	S803C-K63						
				80	S801C-K80		80	S803C-K80						
	2		4	10	S802C-K10	4	10	S804C-K10						
				13	S802C-K13		13	S804C-K13						
				16	S802C-K16		16	S804C-K16						
				20	S802C-K20		20	S804C-K20						
				25	S802C-K25		25	S804C-K25						
				32	S802C-K32		32	S804C-K32						
				40	S802C-K40		40	S804C-K40						
				50	S802C-K50		50	S804C-K50						
				63	S802C-K63		63	S804C-K63						
				80	S802C-K80		80	S804C-K80						
		3	4	10	S802C-K10	4	10	S804C-K10						
				13	S802C-K13		13	S804C-K13						
				16	S802C-K16		16	S804C-K16						
				20	S802C-K20		20	S804C-K20						
				25	S802C-K25		25	S804C-K25						
				32	S802C-K32		32	S804C-K32						
				40	S802C-K40		40	S804C-K40						
				50	S802C-K50		50	S804C-K50						
				63	S802C-K63		63	S804C-K63						
				80	S802C-K80		80	S804C-K80						
100	S802C-K100	100	S804C-K100											
		4	4	10	S802C-K10	4	10	S804C-K10						
				13	S802C-K13		13	S804C-K13						
				16	S802C-K16		16	S804C-K16						
				20	S802C-K20		20	S804C-K20						
				25	S802C-K25		25	S804C-K25						
				32	S802C-K32		32	S804C-K32						
				40	S802C-K40		40	S804C-K40						
				50	S802C-K50		50	S804C-K50						
				63	S802C-K63		63	S804C-K63						
				80	S802C-K80		80	S804C-K80						
100	S802C-K100	100	S804C-K100											





S800S-B

With interchangeable cage terminal

	Number of poles	Rated current		Number of poles	Rated current	
		I_n A	Cat. no.		I_n A	Cat. no.
	1	6	S801S-B6	3	6	S803S-B6
		8	S801S-B8		8	S803S-B8
		10	S801S-B10		10	S803S-B10
		13	S801S-B13		13	S803S-B13
		16	S801S-B16		16	S803S-B16
		20	S801S-B20		20	S803S-B20
		25	S801S-B25		25	S803S-B25
		32	S801S-B32		32	S803S-B32
		40	S801S-B40		40	S803S-B40
		50	S801S-B50		50	S803S-B50
	2	6	S802S-B6	4	6	S804S-B6
		8	S802S-B8		8	S804S-B8
		10	S802S-B10		10	S804S-B10
		13	S802S-B13		13	S804S-B13
		16	S802S-B16		16	S804S-B16
		20	S802S-B20		20	S804S-B20
		25	S802S-B25		25	S804S-B25
		32	S802S-B32		32	S804S-B32
		40	S802S-B40		40	S804S-B40
		50	S802S-B50		50	S804S-B50
	3	6	S802S-B6	4	6	S804S-B6
		8	S802S-B8		8	S804S-B8
		10	S802S-B10		10	S804S-B10
		13	S802S-B13		13	S804S-B13
		16	S802S-B16		16	S804S-B16
		20	S802S-B20		20	S804S-B20
		25	S802S-B25		25	S804S-B25
		32	S802S-B32		32	S804S-B32
		40	S802S-B40		40	S804S-B40
		50	S802S-B50		50	S804S-B50
	4	6	S802S-B6	4	6	S804S-B6
		8	S802S-B8		8	S804S-B8
		10	S802S-B10		10	S804S-B10
		13	S802S-B13		13	S804S-B13
		16	S802S-B16		16	S804S-B16
		20	S802S-B20		20	S804S-B20
		25	S802S-B25		25	S804S-B25
		32	S802S-B32		32	S804S-B32
		40	S802S-B40		40	S804S-B40
		50	S802S-B50		50	S804S-B50
63	S802S-B63	63	S804S-B63			





S800S-C

With interchangeable cage terminal

	Number of poles	Rated current		Number of poles	Rated current	
		I_n A	Cat. no.		I_n A	Cat. no.
	1	6	S801S-C6	3	6	S803S-C6
		8	S801S-C8		8	S803S-C8
		10	S801S-C10		10	S803S-C10
		13	S801S-C13		13	S803S-C13
		16	S801S-C16		16	S803S-C16
		20	S801S-C20		20	S803S-C20
		25	S801S-C25		25	S803S-C25
		32	S801S-C32		32	S803S-C32
		40	S801S-C40		40	S803S-C40
		50	S801S-C50		50	S803S-C50
	2	6	S802S-C6	4	6	S804S-C6
		8	S802S-C8		8	S804S-C8
		10	S802S-C10		10	S804S-C10
		13	S802S-C13		13	S804S-C13
		16	S802S-C16		16	S804S-C16
		20	S802S-C20		20	S804S-C20
		25	S802S-C25		25	S804S-C25
		32	S802S-C32		32	S804S-C32
		40	S802S-C40		40	S804S-C40
		50	S802S-C50		50	S804S-C50
	3	6	S802S-C6	4	6	S804S-C6
		8	S802S-C8		8	S804S-C8
		10	S802S-C10		10	S804S-C10
		13	S802S-C13		13	S804S-C13
		16	S802S-C16		16	S804S-C16
		20	S802S-C20		20	S804S-C20
		25	S802S-C25		25	S804S-C25
		32	S802S-C32		32	S804S-C32
		40	S802S-C40		40	S804S-C40
		50	S802S-C50		50	S804S-C50
	4	6	S802S-C6	4	6	S804S-C6
		8	S802S-C8		8	S804S-C8
		10	S802S-C10		10	S804S-C10
		13	S802S-C13		13	S804S-C13
		16	S802S-C16		16	S804S-C16
		20	S802S-C20		20	S804S-C20
		25	S802S-C25		25	S804S-C25
		32	S802S-C32		32	S804S-C32
		40	S802S-C40		40	S804S-C40
		50	S802S-C50		50	S804S-C50





S800S-D

With interchangeable cage terminal

	Number of poles	Rated current		Number of poles	Rated current	
		I_n A	Cat. no.		I_n A	Cat. no.
	1	6	S801S-D6	3	6	S803S-D6
		8	S801S-D8		8	S803S-D8
		10	S801S-D10		10	S803S-D10
		13	S801S-D13		13	S803S-D13
		16	S801S-D16		16	S803S-D16
		20	S801S-D20		20	S803S-D20
		25	S801S-D25		25	S803S-D25
		32	S801S-D32		32	S803S-D32
		40	S801S-D40		40	S803S-D40
		50	S801S-D50		50	S803S-D50
	2	6	S802S-D6	4	6	S804S-D6
		8	S802S-D8		8	S804S-D8
		10	S802S-D10		10	S804S-D10
		13	S802S-D13		13	S804S-D13
		16	S802S-D16		16	S804S-D16
		20	S802S-D20		20	S804S-D20
		25	S802S-D25		25	S804S-D25
		32	S802S-D32		32	S804S-D32
		40	S802S-D40		40	S804S-D40
		50	S802S-D50		50	S804S-D50
	3	6	S802S-D6	4	6	S804S-D6
		8	S802S-D8		8	S804S-D8
		10	S802S-D10		10	S804S-D10
		13	S802S-D13		13	S804S-D13
		16	S802S-D16		16	S804S-D16
		20	S802S-D20		20	S804S-D20
		25	S802S-D25		25	S804S-D25
		32	S802S-D32		32	S804S-D32
		40	S802S-D40		40	S804S-D40
		50	S802S-D50		50	S804S-D50
	4	6	S802S-D6	4	6	S804S-D6
		8	S802S-D8		8	S804S-D8
		10	S802S-D10		10	S804S-D10
		13	S802S-D13		13	S804S-D13
		16	S802S-D16		16	S804S-D16
		20	S802S-D20		20	S804S-D20
		25	S802S-D25		25	S804S-D25
		32	S802S-D32		32	S804S-D32
		40	S802S-D40		40	S804S-D40
		50	S802S-D50		50	S804S-D50
63	S802S-D63	63	S804S-D63			

S800S-K

With interchangeable cage terminal

	Number of poles	Rated current		Number of poles	Rated current	
		I_n A	Cat. no.		I_n A	Cat. no.
	1	6	S801S-K6	3	6	S803S-K6
		8	S801S-K8		8	S803S-K8
		10	S801S-K10		10	S803S-K10
		13	S801S-K13		13	S803S-K13
		16	S801S-K16		16	S803S-K16
		20	S801S-K20		20	S803S-K20
		25	S801S-K25		25	S803S-K25
		32	S801S-K32		32	S803S-K32
		40	S801S-K40		40	S803S-K40
		50	S801S-K50		50	S803S-K50
	2	6	S802S-K6	4	6	S804S-K6
		8	S802S-K8		8	S804S-K8
		10	S802S-K10		10	S804S-K10
		13	S802S-K13		13	S804S-K13
		16	S802S-K16		16	S804S-K16
		20	S802S-K20		20	S804S-K20
		25	S802S-K25		25	S804S-K25
		32	S802S-K32		32	S804S-K32
		40	S802S-K40		40	S804S-K40
		50	S802S-K50		50	S804S-K50
	3	6	S802S-K6	4	6	S804S-K6
		8	S802S-K8		8	S804S-K8
		10	S802S-K10		10	S804S-K10
		13	S802S-K13		13	S804S-K13
		16	S802S-K16		16	S804S-K16
		20	S802S-K20		20	S804S-K20
		25	S802S-K25		25	S804S-K25
		32	S802S-K32		32	S804S-K32
		40	S802S-K40		40	S804S-K40
		50	S802S-K50		50	S804S-K50
	4	6	S802S-K6	4	6	S804S-K6
		8	S802S-K8		8	S804S-K8
		10	S802S-K10		10	S804S-K10
		13	S802S-K13		13	S804S-K13
		16	S802S-K16		16	S804S-K16
		20	S802S-K20		20	S804S-K20
		25	S802S-K25		25	S804S-K25
		32	S802S-K32		32	S804S-K32
		40	S802S-K40		40	S804S-K40
		50	S802S-K50		50	S804S-K50

Technical data

S800C

General data	
Tripping characteristic	B, C, D, K
Standard	IEC 60947-2, EN 60898-1, UL 1077
Poles	1–4
Rated frequency	50/60 Hz
Data acc. to UL1077	
Rated voltage U	240 V AC (1p, 3p) 277/480Y V AC (1p, 3p) 125 V DC (1p) 250 V DC (2p) 375 V DC (3p) 500 V DC (4p)
Rated current I	10–100 A
Short-circuit breaking capacity I_{cc}	20 kA (240 V AC) 10 kA (277/480Y V AC) 10 kA (500 V DC)
Rated insulation voltage U_i	500 V AC
Reference temperature for tripping characteristic	B, C, D: 30 °C, K: 40 °C
General data	
Electrical and mechanical endurance	Up to 100 A: 6000 electrical/4000 mechanical
Installation	
Terminal	Failsafe cage terminal
Connection (top/bottom) – Cu only	14–2 AWG (10–30 A, solid or stranded) 1–8 AWG (40–100 A, stranded) Single conductor per terminal, 60/75 °C wire (10–30 A), 60 °C wire (40–100 A)
Tightening torque	3.5 Nm/31 in. lb.
Mounting position	Any
Supply side	Any

Technical data

S800S

General data	
Tripping characteristic	B, C, D, K
Standard	IEC 60947-2, EN 60898-1, UL 1077
Poles	1–4
Rated frequency	50/60 Hz
Data acc. to UL1077	
Rated voltage U	600Y/347 V AC
Rated current I	6–63 A
Short-circuit breaking capacity I_{cc}	30 (240 V up to 63 A) 14 (277/480Y V up to 63 A) 6 (346/600Y V up to 40 A, 63 A)
Rated insulation voltage U_i	600 V AC
Reference temperature for tripping characteristic	B, C, D: 30 °C, K: 40 °C
General data	
Electrical and mechanical endurance	6000 electrical/4000 mechanical
Installation	
Terminal	Failsafe cage terminal
Connection (top/bottom) – Cu only	14–2 AWG (10–30 A, solid or stranded) 1–8 AWG (40–100 A, stranded) Single conductor per terminal, 60/75 °C wire (10–30 A), 60 °C wire (40–100 A)
Tightening torque	3.5 Nm/31 in. lb.
Mounting position	Any
Supply side	Any

Approximate dimensions

S800C, S800S

S800C, S800S

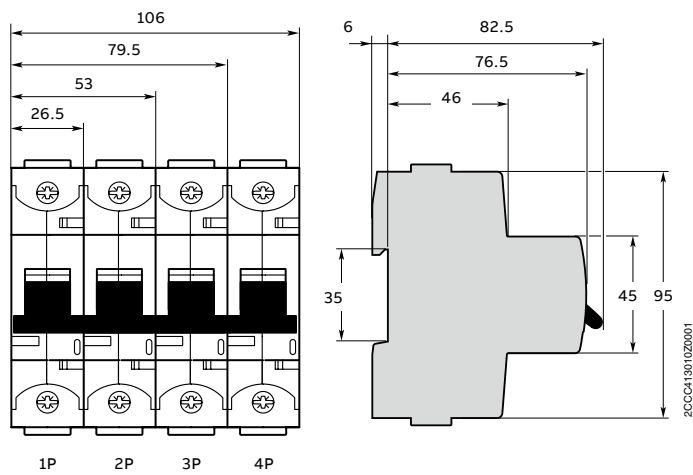

All dimensions shown are in mm.

S800-SOR and S800-UVR

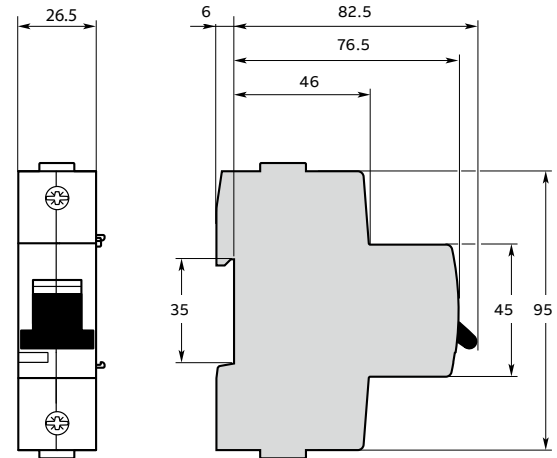

Electronic protection device EPD24-TB-101

For use on the load side of 24 V DC switch mode power supplies

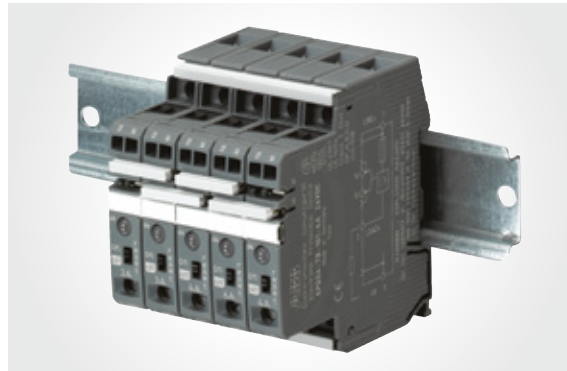

Description

The protection devices EPD24 extend the ABB product range of modular DIN rail components by electronic over-current protection modules for selective protection of 24 V DC load circuits. This protection is achieved by a combination of active electronic current limitation in the case of a short circuit and an overload deactivation from 1.1 x I_N upwards.

If a fault occurs in a load circuit, the protection device EPD24 will detect this rapidly and reliably, disable the power output transistor and hence interrupt the current flow in the defective circuit. The maximum possible over-current is always limited to 1.3 to 1.8 times the selected rated current. An activation of capacitive loads up to 20,000 µF is possible, deactivation only occurring in the case of overloads or short circuits. Selective deactivation of the defective current circuit means undefined error states and a complete system stop are prevented.

Features

- Selective load protection, one electronic tripping characteristic
- Active current limitation for safe connection of capacitive loads up to 20,000 µF and on overload/short circuit
- Current ratings 0.5 A to 12 A
- Reliable overload disconnection with 1.1 x I_N plus
- Manual ON/OFF button
- Clear status and failure indication through LED and integrated auxiliary contact
- Integral fail-safe element adjusted to current rating
- Width per unit only 12.5 mm
- Rail mounting
- Easy wiring through busbar LINE+ and 0 V as well as signal bars
- UL and CSA approvals allow international use of the devices

Approvals

Authority	Voltage rating	Current ratings
UL 2367	24 V DC	0.5–12 A
UL 1604 (class I, div. 2, groups A, B, C, D)	24 V DC	0.5–12 A
UL 508	24 V DC	0.5–12 A
CSA C22.2 No. 213 (class I, division 2)	24 V DC	0.5–12 A
CSA C22.2 No. 142	24 V DC	0.5–12 A
CSA C22.2 No. 14	24 V DC	0.5–12 A

EPD24

Ordering information

Electronic protection devices

Rated current I_n A	Weight 1 piece in kg	Packing unit	Cat. no.
0.5	0.065	4	EPD24-TB-101-0.5A
1	0.065	4	EPD24-TB-101-1A
2	0.065	4	EPD24-TB-101-2A
3	0.065	4	EPD24-TB-101-3A
4	0.065	4	EPD24-TB-101-4A
6	0.065	4	EPD24-TB-101-6A
8	0.065	4	EPD24-TB-101-8A
10	0.065	4	EPD24-TB-101-10A
12	0.065	4	EPD24-TB-101-12A

Accessories

	Cat. no.	Weight 1 piece in kg	Packing unit
Busbars for LINE+ and 0 V, grey insulation, length 500 mm ¹⁾	EPD-BB500	0.20	10
Signal bars for auxiliary contacts, grey insulation, length 21 mm	EPD-SB21	0.04	10

1) Ampacity at one line entry $I_{max} = 50$ A (Recommendation: mid line entry)
Ampacity at two line entries $I_{max} = 63$ A

Diagram

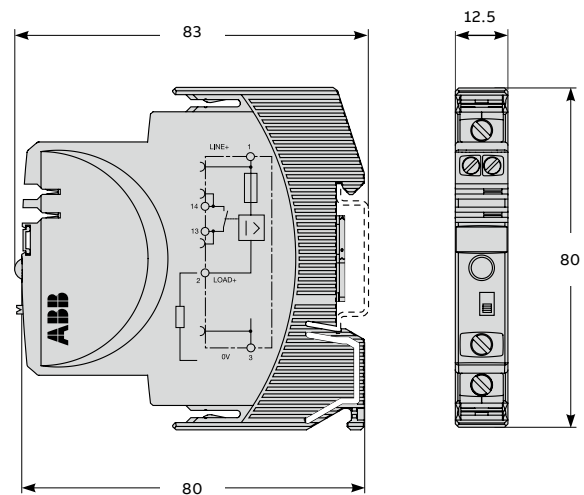

All dimensions shown are in mm.

Notes

—
Notes

Additional information

We reserve the right to make technical changes or modify the contents of this document without prior notice. With regard to purchase orders, the agreed particulars shall prevail. ABB Inc does not accept any responsibility whatsoever for potential errors or possible lack of information in this document.

We reserve all rights in this document and in the subject matter and illustrations contained therein. Any reproduction utilization of its contents – in whole or in parts – is forbidden without prior written consent of ABB Inc.



—

ABB Inc.

Electrification Products
860 Ridge Lake Blvd.
Memphis, TN 38120
abb.com/lowvoltage

Customer Service: 800-816-7809
7:00 a.m. - 5:30 p.m., CST, Monday-Friday
elec_custserv@tnb.com

Technical Support: 888-385-1221, Option 1
7:00 a.m. - 5:00 p.m., CST, Monday-Friday
lvps.support@us.abb.com

—

We reserve the right to make technical changes or modify the contents of this document without prior notice. With regard to purchase orders and/or contracts, the agreed particulars shall prevail. ABB Inc. does not accept any responsibility whatsoever for potential errors or possible lack of information in this document.

We reserve all rights in this document and in the subject matter and illustrations contained therein. Any reproduction or utilization of its contents – in whole or in parts – is forbidden without prior written consent of ABB Inc.

© Copyright 2018 ABB. All rights reserved.